



**CITY OF FAYETTEVILLE**  
**Fayetteville Area System of Transit (FAST)**

**INVITATION TO BID**  
**1550 Skibo Road Bus Stop & Sidewalk**  
**Construction Project**

**COF1517014**

**DATE ISSUED:** July 07, 2026

**BIDS DUE:** July 30, 2026 at 2:00 p.m.

**FUNDING SOURCE:** FTA — \$40,000 / Local Funds — \$10,000

**ISSUED BY:** City of Fayetteville, North Carolina

**PRIMARY CONTACT:** Kimberly Toon, CLGPO, Purchasing Manager

[kimberlytoon@fayettevillenc.gov](mailto:kimberlytoon@fayettevillenc.gov)

(910) 433-1942

*OFFERORS ARE NOT REQUIRED TO RETURN THIS FORM.*



*A message from the City of Fayetteville City Manager, Dr. Douglas J. Hewett, ICMA-CM*

The City of Fayetteville is fully committed to providing Small Local Business Enterprises (SLBEs) and small businesses an equal opportunity to participate in all aspects of City contracting, including but not limited to participation in the procurement of contracts relating to construction, professional services, equipment, supplies, and improvements to facilities throughout the City.

It is the policy of the City to prohibit discrimination against any person or business in pursuit of these opportunities on the basis of race, sex, color, religion, national origin, age, or disability, and to conduct its contracting and purchasing programs so as to prevent such discrimination. The City is committed to following all applicable federal, state, and local laws as they relate to procurement practices.

### **Small Business Participation Commitment**

The City will actively seek and identify qualified small businesses, including SLBEs, and offer them the opportunity to participate in the procurement of contracts for all City purchasing and service contracts as well as construction and repair contracts. The City aspires to spend 40% of its eligible contract dollars with small local suppliers and contractors.

### **Small Business Enterprise Program**

The City's Charter has been amended by the General Assembly (H.B. 198) to establish a small business enterprise program to promote the development of small local businesses. The City is authorized to establish bid and proposal specifications that include measures to enhance participation by small business enterprises located in Cumberland and Hoke Counties, including:

- Arranging solicitations, specifications, and contract requirements to facilitate small business participation
- Providing technical assistance and capacity building programs
- Carrying out information and communication programs on contracting procedures and opportunities
- Implementing outreach programs to identify and engage qualified small businesses
- Offering supportive services to help small businesses compete effectively
- Ensuring prompt payment to subcontractors
- Simplifying bonding and insurance requirements where appropriate

### **Federal and State-Funded Projects - Important Notice**

In accordance with state directive following the U.S. Department of Transportation's October 3, 2025 Interim Final Rule to 49 CFR Part 26:

# FAYETTEVILLE

AMERICA'S CAN DO CITY

## For Federally-Funded Contracts:

- No DBE goals may be established for federally-funded contracts until further guidance is provided by the state
- All existing DBE certifications are in suspended status pending Unified Certification Program (UCP) reevaluation under new individualized disadvantage standards
- Firms are not required to submit DBE participation commitments at this time

## For State-Funded Contracts:

- No MB/WBE goals may be established for state-funded contracts until further guidance is provided by the state

The City will continue to facilitate participation by all qualified small businesses through the measures listed above and will resume DBE and MB/WBE program activities once the state provides further guidance.

## Equal Opportunity for All

The City is committed to:

- Providing equal access to contracting opportunities for all qualified businesses
- Removing barriers to small business participation
- Supporting economic development and capacity building in our community
- Ensuring fair and open competition in all procurements
- Maintaining compliance with all applicable federal, state, and local requirements
- Supporting diversity in our supplier and contractor base

For more information or questions about the SLBE policy, please contact the Purchasing Division at 910-433-1942.

CITY OF FAYETTEVILLE

  
Dr. Douglas J. Hewett, ICMA-CM  
City Manager

## **NOTICE TO BIDDERS**

Pursuant to N.C. Gen. Stat. § 143-131 (Informal Bidding Procedures), informal bids will be received by the City of Fayetteville / Fayetteville Area System of Transit (FAST), until **2:00 p.m., July 30, 2026**, at City Hall, 433 Hay Street, Fayetteville, North Carolina, 28301, at which time they will be opened and considered for the purchase of the following:

### **1550 Skibo Road Bus Stop & Sidewalk Construction Project**

Bids may be mailed to the City Purchasing Office, Attn: Kimberly Toon, 433 Hay Street, Fayetteville, NC 28301, or may be delivered in person or by express delivery service to 433 Hay Street, Fayetteville, NC 28301. **Bids submitted by facsimile or email will not be accepted.**

A public bid opening will be held at **2:00 p.m. on July 30, 2026**, at City Hall, 433 Hay Street, Fayetteville, NC 28301, for the project entitled **“1550 Skibo Road Bus Stop & Sidewalk Construction Project.”**

Bid documents may be obtained in the Purchasing Office of the City of Fayetteville, 2nd floor, City Hall, 433 Hay Street, Fayetteville, North Carolina, between the hours of 8:00 a.m. and 5:00 p.m., Monday through Friday, or by email request to [kimberlytoon@fayettevillenc.gov](mailto:kimberlytoon@fayettevillenc.gov).

This procurement is funded in part with financial assistance from the Federal Transit Administration (FTA) under 49 U.S.C. Chapter 53 (\$40,000 FTA / \$10,000 City of Fayetteville local funds). FTA requirements set forth in Attachment O govern this procurement. Federal financial assistance does not constitute an endorsement of the Contractor selected for award.

The City reserves the right to reject any or all bids and to waive all informalities concerning bids, and to award the contract to the lowest, responsive, responsible bidder taking into consideration quality, performance, and the time specified in the proposals for the performance of the contract, pursuant to N.C. Gen. Stat. § 143-131(a).

**City of Fayetteville / FAST**

**Kimberly Toon, CLGPO**

**Purchasing Manager**

## **TABLE OF CONTENTS**

### **SECTION 1: INTRODUCTION**

- 1.1 Statement of Intent
- 1.2 Background
- 1.3 Pre-Bid Meeting
- 1.4 Permits
- 1.5 Use of Brand or Trade Names
- 1.6 Project Contacts

### **SECTION 2: SCOPE OF WORK**

- 2.1 Scope and Services to Be Performed
- 2.2 Period of Performance
- 2.3 Bid Document Attachments

### **SECTION 3: BID REQUIREMENTS**

- 3.1 Information Required from the Contractor
- 3.2 General Bid Requirements
- 3.3 Changes to ITB Document (Addenda)
- 3.4 Questions
- 3.5 Bid Opening
- 3.6 Examination of Bids and Determination of Responsiveness

### **SECTION 4: AWARD CRITERIA**

- 4.1 Selection
- 4.2 Selection Process Protest Procedures
- 4.3 Acceptance or Rejection of Bids
- 4.4 Schedule of Events

### **SECTION 5: GENERAL BID CONDITIONS**

### **SECTION 6: ATTACHMENTS**

- Attachment A — Bid Form
- Attachment B — Bid Price Sheet
- Attachment C — Minimum Insurance Requirements
- Attachment D — E-Verify Affidavit
- Attachment E — Sales/Use Tax Statement
- Attachment F — Iran Divestment Act Certificate
- Attachment G — Companies Boycotting Israel Certificate
- Attachment H — Conflict of Interest Certificate
- Attachment I — Non-Collusion
- Attachment J — Davis-Bacon Wage Rates
- Attachment K — SDBE/M/WBE Forms
- Attachment L — Lobbying Certification

Attachment M — Terminating Illegal Discrimination Certification

Attachment N — ITB Response Checklist

Attachment O — FTA Requirements

Attachment O-1 — Buy America Certification Form

Exhibit A — Drawings

Exhibit B — Draft Contract Agreement

**INVITATION TO BID  
FOR  
1550 SKIBO ROAD BUS STOP & SIDEWALK CONSTRUCTION PROJECT**

**SECTION 1: INTRODUCTION**

**1.1 Statement of Intent**

The City of Fayetteville / Fayetteville Area System of Transit (“FAST”) invites qualified and experienced contractors to submit Bids for the **1550 Skibo Road Bus Stop & Sidewalk Construction Project**. FAST reserves the right to reject any or all Bids.

To obtain a copy of this Invitation to Bid (ITB), Contractors shall download the document from the City of Fayetteville website at: <https://www.fayettevillenc.gov/City-Departments/Finance/Purchasing/Bid-Opportunities>

Bids will be received until **2:00 p.m. on July 30, 2026** at City Hall’s Purchasing Department located at 433 Hay Street, Fayetteville, North Carolina 28301. Questions shall be directed to Kimberly Toon, Purchasing Manager, at [kimberlytoon@fayettevillenc.gov](mailto:kimberlytoon@fayettevillenc.gov).

**1.2 Background**

The City of Fayetteville’s Fayetteville Area System of Transit (FAST) is a municipal transit department of the City of Fayetteville, North Carolina. FAST provides public transportation services to residents of the Fayetteville metropolitan area. This project involves the construction of bus stop infrastructure and associated sidewalk improvements at 1550 Skibo Road to enhance transit accessibility.

This project is funded with financial assistance from the Federal Transit Administration (FTA) under 49 U.S.C. Chapter 53 (\$40,000 FTA / \$10,000 City local funds). All applicable FTA procurement requirements govern this solicitation. Contractor shall furnish all materials, tools, machinery, equipment, apparatus, labor, and all means necessary to perform all tasks detailed in the Scope of Work.

**1.3 Pre-Bid Meeting**

A **Non-Mandatory Pre-Bid Conference** will be held at **339 Alexander Street, Fayetteville, NC 28301, and via Microsoft Teams, at 10:00 a.m. on July 16, 2026**. The purpose of this meeting is to offer prospective bidders an opportunity to familiarize themselves with the site and ask questions pertaining to the project and Contract Documents.

<b>Pre-Bid Meeting</b>	<b>Optional Virtual Attendance Available</b>
<b>Date:</b>	July 16, 2026
<b>Time:</b>	10:00 a.m. EST
<b>In-Person Location:</b>	339 Alexander Street, Fayetteville, NC 28301
<b>Microsoft Teams Link:</b>	<a href="https://teams.microsoft.com/meet/243065985130344?p=8o11OawI5hfyjfcf9U">https://teams.microsoft.com/meet/243065985130344?p=8o11OawI5hfyjfcf9U</a>
<b>Meeting ID:</b>	243 065 985 130 344
<b>Passcode:</b>	Fy6nj7g2

#### **1.4 Permits**

The Contractor is responsible to obtain, at its own expense, all permits, certifications, and/or licenses required to complete the construction project. Copies of all inspections and permits shall be provided to FAST for record-keeping. All work must comply with all safety, electrical, and building codes of the State of North Carolina and applicable local ordinances.

#### **1.5 Use of Brand or Trade Names**

The use of brand names, trade names, types, styles, model numbers, and serial numbers is intended to be descriptive only and not intended to restrict competition. Specific brand names will be used as a comparative measure of safety, quality, and performance against all Bid submissions. Other brand names, types, styles, and model numbers must be “equal” and meet the minimum requirements of the specified product.

#### **1.6 Project Contacts**

**All Contact:** All questions, comments, correspondence, and Bid packages shall be transmitted to the attention of the following individual, serving as the Owner’s Representative during the bidding process:

**Kimberly Toon, CLGPO, Purchasing Manager**  
**City of Fayetteville — Purchasing Division**

433 Hay Street, Fayetteville, NC 28301

Office: (910) 433-1942

[kimberlytoon@fayettevillenc.gov](mailto:kimberlytoon@fayettevillenc.gov)

## **SECTION 2: SCOPE OF WORK**

### **2.1 Scope and Services to Be Performed**

This is an FTA-funded Transit Bus Stop project located at **1550 Skibo Road, Fayetteville, NC** (multiple bus stop locations along the Skibo Road corridor). The project consists of the following work, including but not limited to:

- **Mobilization and demobilization**
- **Traffic control and maintenance of pedestrian and vehicle access throughout construction**
- **Clearing and grubbing**
- **Removal and installation of concrete curb and gutter**
- **Asphalt removal and pavement patching**
- **ADA-compliant ramps and truncated dome detectable warning surfaces**
- **Thermoplastic pavement markings**
- **Aggregate base course (ABC stone)**
- **Concrete sidewalk construction (various widths and thicknesses per plans)**
- **Concrete bus stop pad installation**
- **Storm drainage improvements including concrete pipe and junction boxes (Location D)**
- **Topsoil placement and sod installation**
- **Tree and shrub removal (Location C)**

**NOTE:** The plans, technical specifications, and full bid price sheet are attached as Exhibit A and Attachment B respectively. Contractor is required to review the drawings in detail before submitting a bid. All work shall comply with City of Fayetteville Standard Details and Specifications.

**ADA Compliance:** All constructed facilities must comply with the Americans with Disabilities Act of 1990 (ADA), 42 U.S.C. § 12101 et seq., applicable DOT regulations at 49 C.F.R. Part 37, and the ADA Accessibility Guidelines (ADAAG). This requirement is non-negotiable and cannot be waived.

### **2.2 Period of Performance**

This is a **90-calendar-day project**. The Contractor shall commence work on the date specified in the Notice to Proceed issued by the City and shall achieve Substantial Completion within 90

calendar days thereafter. Time is of the essence. Liquidated damages for delay shall be as set forth in the Draft Contract Agreement (Exhibit B). The Contract Start Date will be provided in the Notice to Proceed following award.

### **2.3 Bid Document Attachments**

This Invitation to Bid includes the following attachments and exhibits:

- 1. Attachment A — Bid Form
- 2. Attachment B — Bid Price Sheet (Unit Price Schedule)
- 3. Attachment C — Minimum Insurance Requirements
- 4. Attachment D — E-Verify Affidavit
- 5. Attachment E — Contractor’s Statement of Sales/Use Tax
- 6. Attachment F — Iran Divestment Act Certificate
- 7. Attachment G — Companies Boycotting Israel Divestment Act Certification
- 8. Attachment H — Certificate Regarding Conflict of Interest
- 9. Attachment I — Non-Collusion
- 10. Attachment J — Davis-Bacon Wage Rates (Current Wage Determination)
- 11. Attachment K — SDBE/M/WBE Forms
- 12. Attachment L — Lobbying Certification (Best Practice — See Note)
- 13. Attachment M — Terminating Illegal Discrimination Certification
- 14. Attachment N — ITB Response Checklist
- 15. Attachment O — Federal Transit Administration (FTA) Requirements
- 16. Attachment O-1 — Buy America Certification Form
- 17. Exhibit A — Drawings (Sealed by Licensed NC Professional Engineer)
- 18. Exhibit B — Draft Contract Agreement

## **SECTION 3: BID REQUIREMENTS**

### **3.1 Information Required from the Contractor**

**Contractor’s submission must include all of the following:**

1. Signed and completed Bid Form (Attachment A)
2. Signed and completed Bid Price Sheet (Attachment B) with all unit price line items completed
- 3. Project Personnel:** Identify key Construction Project Manager and superintendent by name and relevant experience
- 4. Key Point of Contact:** List main point of contact and Project Manager with direct phone number and email
- 5. Schedule and Work Plan:** Provide a project schedule showing all construction activities and the timeframe for completing the 90-day project.

6. **Subcontractors:** Provide a listing of all subcontractors' names, addresses, and roles in this contract
7. Copy of valid North Carolina General Contractor License (N.C. Gen. Stat. § 87-1 et seq.)
8. Proof of insurance as required in Attachment C
9. E-Verify Affidavit (Attachment D)
10. Contractor's Statement of Sales/Use Tax (Attachment E)
11. Iran Divestment Act Certificate (Attachment F)
12. Companies Boycotting Israel Divestment Act Certification Form (Attachment G)
13. Certificate Regarding Conflict of Interest (Attachment H)
14. Non-Collusion Statement (Attachment I)
15. Davis-Bacon Wage Rates Acknowledgment (Attachment J)
16. SDBE/M/WBE Forms (Attachment K)
17. Lobbying Certification (Attachment L)
18. Terminating Illegal Discrimination Certification (Attachment M)
19. Completed ITB Response Checklist (Attachment N)
20. **Buy America Certification Form (Attachment O-1) — REQUIRED for FTA-funded projects**

### **3.2 General Bid Requirements**

For a Bid to be considered, all documents required by this ITB must be submitted in the specified format. The Bid submission shall follow the format and order set forth in Section 3.1 above.

- Submit one (1) original and three (3) additional copies of the Bid, and one USB Flash Drive containing electronic versions of all submission documents.
- All Bids become the property of the City of Fayetteville upon submission.
- Bids shall be submitted in a sealed envelope clearly marked: **"ITB — 1550 Skibo Road Bus Stop & Sidewalk Construction Project."**
- The City will receive Bids only by personal delivery, courier/delivery service, or regular U.S. mail. **Bids submitted by facsimile or email will not be accepted.**
- Bids must be received by the Purchasing Office before **2:00 p.m. on July 30, 2026. No Bids received after this date and time will be accepted or considered.**
- Because this is an informal bid under N.C. Gen. Stat. § 143-131, bid bonds are not required. However, the City will reject any bid that is not signed by an authorized representative of the Contractor.

**Delivery Addresses:**

<b>Personal Delivery or Courier Service</b>	<b>U.S. Mail</b>
City Hall, 433 Hay Street Fayetteville, NC 28301 Attn: Kimberly Toon, Purchasing Manager	City of Fayetteville, Purchasing Office 433 Hay Street, Fayetteville, NC 28301 Attn: Kimberly Toon, Purchasing Manager

**Addendum Acknowledgment:** Please acknowledge receipt of any addendum received on the Bid Form (Attachment A). Bids that fail to acknowledge receipt of all addenda may be considered non-responsive.

**3.3 Changes to ITB Document (Addenda)**

Any changes to this ITB document will be made by written addenda. Upon issuance, addenda will be considered part of the ITB document and will prevail over inconsistent or conflicting provisions in the original ITB document. All addenda will be posted to the City of Fayetteville website at [www.fayettevillenc.gov](http://www.fayettevillenc.gov). Contractors shall acknowledge receipt of all addenda in the Bid Form (Attachment A).

**3.4 Questions**

Any questions regarding this ITB shall be directed **in writing only** to Kimberly Toon, Purchasing Manager. All questions must be submitted in writing before **5:00 p.m. on July 21, 2026**. Questions received after this deadline may not receive a response. Questions shall be emailed to [kimberlytoon@fayettevillenc.gov](mailto:kimberlytoon@fayettevillenc.gov). Responses to questions will be posted on the City of Fayetteville website ([www.fayettevillenc.gov](http://www.fayettevillenc.gov)) as addenda.

**No oral interpretations:** Oral explanations or instructions given before the bid opening will not be binding. Only written addenda shall modify the ITB.

**3.5 Bid Opening**

Bids will be opened publicly in the presence of bidders' designated representatives who choose to attend, at **2:00 p.m. on July 30 26, 2026** at City Hall, 433 Hay Street, Fayetteville, NC 28301. Although this procurement uses informal bidding procedures under N.C. Gen. Stat. § 143-131, FAST is conducting a public opening as a matter of transparency and to assure FTA procurement integrity under 2 CFR § 200.319.

Because this is an informal bid under N.C. Gen. Stat. § 143-131, bid information is confidential from receipt until the contract is formally awarded. Bids received will not be disclosed to competing bidders prior to award except at the public bid opening. There is no expressed or implied obligation for FAST to reimburse Contractors for any expenses incurred in preparing Bids in response to this ITB.

**3.6 Examination of Bids and Determination of Responsiveness**

Information relating to the examination, evaluation, and comparison of Bids, and recommendations for award, shall not be disclosed to bidders or other persons not initially concerned with the evaluation process until the award to the successful bidder has been announced.

Any effort by a bidder to influence the evaluation process or award decision may result in rejection of that bidder's Bid.

**Responsive Bid:** A responsive bid is one that conforms to all material terms, conditions, and specifications of the bidding document. A material deviation is one that affects the scope, quality, or performance of the work in any substantial way; limits the City's rights or the bidder's obligations in a way inconsistent with the bidding documents; or would affect unfairly the competitive position of other bidders.

**Non-Responsive Bids:** Bids that are not responsive to the requirements of this ITB, including failure to provide required certifications or FTA-required documents, may be rejected. Bids may not be made responsive after opening by correction of material deviations.

**Minor Irregularities:** The City may waive minor irregularities in any Bid that would not create an unfair competitive advantage to the submitting bidder or prejudice other bidders.

## **SECTION 4: AWARD CRITERIA**

### **4.1 Selection**

The City of Fayetteville will make the award to the **lowest responsive, responsible Contractor** pursuant to N.C. Gen. Stat. § 143-131(a), taking into consideration quality, performance, and the time specified in the proposals for the performance of the contract. A Contractor's record of performance on past projects, financial stability, and ability to perform the work may be considered in the responsibility determination.

The City may waive any irregularities in any Bid that would not prejudice other Contractors. The City further reserves the right to negotiate when bids exceed the available budget amount.

**Federal Procurement Standards:** This procurement is subject to the requirements of 2 C.F.R. §§ 200.318–200.327 (Federal Uniform Guidance Procurement Standards). Award shall be made to the responsible Contractor submitting the lowest responsive bid. The City shall not award on any other basis.

### **4.2 Selection Process Protest Procedures**

Protests related to this procurement must be addressed to the **Purchasing Manager for the City of Fayetteville**, 433 Hay Street, Fayetteville, NC 28301, and shall be received **in writing within five (5) calendar days of bid award**. Responses will be provided in writing by email and first-class mail not later than seven (7) calendar days following receipt of the protest by the Purchasing Manager.

**FTA Protest Escalation:** A protester must exhaust all administrative remedies with the City of Fayetteville before pursuing a protest with the Federal grantor agency. Reviews of protests by the Federal grantor agency (FTA) are limited to: (1) violations of Federal law or regulations and the standard of this section (violations of state or local law will be under the jurisdiction of state or local authorities); and (2) violations of the grantee's protest procedures for failure to review a complaint or protest. Protests received by FTA other than those specified above will be referred to the City.

### **4.3 Acceptance or Rejection of Bids**

Failure to respond to any of the requirements outlined in this ITB, or failure to include any required documents, may disqualify the Contractor's Bid submission.

The City has the sole right to: select the successful Contractor for award; reject any and all Bids; re-solicit for new Bids; and accept the most favorable Bid from the standpoint of cost, quality, delivery date, and technical capability consistent with N.C. Gen. Stat. § 143-131. No Contractor shall have any cause of action against the City arising out of the methods by which Bids are assessed. Selection shall be at the sole discretion of the City, subject to federal procurement standards.

Submission of a Bid indicates acceptance by the Contractor of the conditions contained in this ITB unless clearly and specifically noted in the Bid submitted and confirmed in the Contract between the City and the selected Contractor.

### **4.4 Schedule of Events**

<b>DATE</b>	<b>EVENT</b>
<b>July 7, 2026</b>	ITB Issued / Posted to City Website
<b>July 16, 2026 — 10:00 a.m.</b>	Non-Mandatory Pre-Bid Conference (In Person and Microsoft Teams)
<b>July 21, 2026 — 5:00 p.m.</b>	Deadline to Submit Written Questions
<b>Within 3 business days of question deadline</b>	Responses to Questions Posted as Addenda
<b>July 30, 2026 — 2:00 p.m.</b>	Bid Submission Deadline / Public Bid Opening
<b>Approximately 2 weeks after bid opening</b>	Contract Award (City Council or City Manager Approval)
<b>TBD</b>	Notice to Proceed Issued
<b>90 calendar days from Notice to Proceed</b>	Projected Substantial Completion

## **SECTION 5: GENERAL BID CONDITIONS**

### **5.1 Notice of Informal Solicitation**

This solicitation is being conducted as an informal bid pursuant to **N.C. Gen. Stat. § 143-131**. The estimated total contract value is \$50,000 (\$40,000 FTA / \$10,000 City local funds). At this value: (a) bid bonds are not required by state law; (b) performance and payment bonds are not required under 2 C.F.R. § 200.325 (applicable threshold is \$150,000) or N.C. Gen. Stat. § 44A-26 (applicable threshold is project total exceeding \$300,000); and (c) sealed bid and minimum bid count requirements of N.C. Gen. Stat. § 143-129 do not apply. Davis-Bacon Act prevailing wages apply because the project is funded with federal financial assistance exceeding \$2,000 (40 U.S.C. § 3141 et seq.).

### **5.2 Method of Response**

Contractor shall submit Bids in accordance with Section 3.2. Bids must include all required forms and certifications. The Bid Form (Attachment A) must be signed by an authorized representative of the Contractor. Unsigned bids will not be considered.

### **5.3 Acceptance of Terms and Conditions**

Submission of a Bid constitutes acceptance of all terms and conditions contained in this ITB and the Draft Contract Agreement (Exhibit B), including all FTA requirements in Attachment O, unless clearly and specifically noted in the Bid and confirmed in the Contract.

### **5.4 False, Incomplete, or Unresponsive Statements**

The accuracy and completeness of information included in the Bid is the responsibility of the Contractor. Material misrepresentations or false statements in a Bid, or in any certification required by this ITB, may result in disqualification of the Bid, termination of any resulting contract, and referral to appropriate authorities. Providing false information on a federal certification may result in civil and criminal penalties under 18 U.S.C. § 1001 and applicable program fraud statutes.

### **5.5 Clear and Concise Submission**

All Bid documents shall be clear, legible, and unambiguous. Handwritten corrections must be initialed by the authorized representative. If discrepancies exist between unit prices and extended amounts, unit prices shall govern.

### **5.6 Prime Contractor Responsibilities**

The awarded Contractor shall be the Prime Contractor and shall bear full responsibility for all work under the contract, including work performed by subcontractors. The Prime Contractor:

- **Shall maintain a valid NC General Contractor License** (N.C. Gen. Stat. § 87-1 et seq.) throughout the duration of the project;
- **Shall require all specialty trade subcontractors** (electrical, plumbing/HVAC, etc.) to hold appropriate NC specialty trade licenses;
- **Shall comply with all Davis-Bacon prevailing wage requirements** and submit weekly certified payrolls as required by the Davis-Bacon Act, 40 U.S.C. § 3141 et seq., for the FTA-funded portion of the work;

- **Shall comply with all FTA requirements** set forth in Attachment O, including Buy America, civil rights, and DBE/SDBE requirements;
- **Shall not begin work** until a written Notice to Proceed is issued by the City;
- **Shall pay all subcontractors** for satisfactory work within seven (7) days of receiving payment from the City pursuant to N.C. Gen. Stat. § 143-134.1;
- The **clause regarding subcontract substitution** applies to both DBE and non-DBE subcontracts: Contractor shall not substitute any subcontractor listed in the Bid without prior written approval of the City. Requests for substitution must include documented good cause, written notice to the affected subcontractor, and good faith efforts to find a qualified replacement.

## **SECTION 6: ATTACHMENTS**

The following attachments and exhibits are incorporated into and made a part of this ITB:

- Attachment A — Bid Form
- Attachment B — Bid Price Sheet (Unit Price Schedule)
- Attachment C — Minimum Insurance Requirements
- Attachment D — E-Verify Affidavit
- Attachment E — Contractor’s Statement of Sales/Use Tax
- Attachment F — Iran Divestment Act Certificate
- Attachment G — Companies Boycotting Israel Divestment Act Certification
- Attachment H — Certificate Regarding Conflict of Interest
- Attachment I — Non-Collusion
- Attachment J — Davis-Bacon Wage Rates (Current Wage Determination)
- Attachment K — SDBE/M/WBE Forms
- Attachment L — Lobbying Certification (Best Practice — See Note)
- Attachment M — Terminating Illegal Discrimination Certification
- Attachment N — ITB Response Checklist
- Attachment O — Federal Transit Administration (FTA) Requirements
- Attachment O-1 — Buy America Certification Form
- Exhibit A — Drawings (Sealed by Licensed NC Professional Engineer)
- Exhibit B — Draft Contract Agreement



The undersigned, having carefully examined the ITB documents including the Scope of Work, Specifications, Drawings (Exhibit A), Draft Contract Agreement (Exhibit B), and all attachments, hereby proposes to furnish all labor, materials, equipment, and services necessary to complete the **1550 Skibo Road Bus Stop & Sidewalk Construction Project** in strict accordance with the Contract Documents for the amount shown on the Bid Price Sheet (Attachment B).

**Certification:**

The undersigned certifies that: (1) this bid has been arrived at independently without collusion or agreement with any other bidder; (2) the firm has the financial capability and experience to perform the work; (3) all information in this Bid Form is accurate and complete; (4) the firm has reviewed and acknowledges all FTA requirements in Attachment O; and (5) the firm knows of no personal or organizational conflict of interest prohibited under federal, state, or local law.

I certify (or declare) under penalty of perjury under the laws of the State of North Carolina that the foregoing is true and correct.

**Authorized Signature:**

**Date:**

\_\_\_\_\_

\_\_\_\_\_

**Print Name:**

**Title:**

\_\_\_\_\_

\_\_\_\_\_

**ATTACHMENT B | 00 41 16 Bid Form Exhibit A**

**BID PRICE SHEET — UNIT PRICE SCHEDULE**

**1550 Skibo Road Bus Stop & Sidewalk Construction Project**

**NOTE ON BID TOTAL:** Attachment B must clearly state a total bid amount that will govern contract award. The total of all bid groups A through D shall be the basis for award. The estimated total project value is \$50,000; bids significantly exceeding this amount may result in re-solicitation.

**RETAINAGE:** The City will retain five percent (5%) of each progress payment as security for Contractor's performance. Retainage will be released in accordance with N.C. Gen. Stat. § 143-134.1 and the Draft Contract Agreement (Exhibit B).

# ATTACHMENT B | Bid Price Sheet Unit Price Schedule

00 41 16 Bid Form Exhibit A

2/10/2026

<b>Project:</b>	1550 Skibo Road - Walmart Bus Stop & Sidewalk		<b>Project No.:</b>
<b>Owner:</b>			
<b>Engineer:</b>			
<b>Offeror:</b>			

**Base Bid**

Item No.	SDT No.	Section	Item Description	Unit	Estimated Quantity	Unit Price	Extended Amount	
<b>Items in Base Bid (excluding Allowances) per Section 01 29 01 "Measurement and Basis for Payment"</b>								
A-01		00170	Mobilization	LS	1			
A-02		00491	Traffic Control	LS	1			
A-03		00405	Clearing and Grubbing	AC	1			
A-04		00406	Remove Existing Concrete Curb & Gutter	LF	114			
A-05		00406	Remove Existing Concrete Sidewalk	SY	2			
A-06		00495	Remove Existing Pavement Markings (Lines)	LF	30			
A-07		00495	Remove Existing Pavement Markings (STOP)	EA	2			
A-08	SD-1	00455	Concrete Curb & Gutter (24 in. Vertical)	LF	8			
A-09	SD-1	00455	Concrete Curb & Gutter (24 in. Spill-off)	LF	114			
A-10	SD-12	00455	Concrete Sidewalk (5 ft. wide, 4 in. thick)	SY	54			
A-11	SD-12	00455	Concrete Bus Stop (5x20 ft. wide, 5 in. thick)	SY	11			
A-12	SD-12	00455	Concrete Pavement (10 in. thick, Wire Mesh Reinforcement, 4500 PSI)	SY	129			
A-13	SD-2.4	00455	Concrete Curb Ramp (Directional)	EA	1			
A-14	SD-2.6	00455	Truncated Domes (2x5 ft.)	EA	1			
A-15		412	Incidental Stone Base (ABC stone)	TN	1			
A-16	SD-12	02931	Sod	SY	60			
A-17	SD-11	00451	Permanent Pavement Patch (Asphalt)	TN	2			
A-18	SP		Bus Stop Sign	EA	1			
A-18		00495	Thermoplastic Pavement Markings (6 ft. wide, High Visibility Crosswalk)	SY	27			
A-19		00495	Thermoplastic Pavement Markings (24 in. wide Stop bar)	LF	22			
A-20		00496	Thermoplastic Pavement Markings (STOP)	EA	2			
A-21					-	-	-	
A-22					-	-	-	
A-23					-	-	-	
A-24					-	-	-	
A-25					-	-	-	
A-26					-	-	-	
A-27					-	-	-	
A-28					-	-	-	
A-29					-	-	-	
A-30					-	-	-	
A-31					-	-	-	
A-32					-	-	-	
A-33					-	-	-	
A-34					-	-	-	
A-35					-	-	-	
A-36					-	-	-	
A-37					-	-	-	
A-38					-	-	-	
A-39					-	-	-	
A-40					-	-	-	
A-41					-	-	-	
A-42					-	-	-	
A-43					-	-	-	
A-44					-	-	-	
A-45					-	-	-	
A-46					-	-	-	
A-47					-	-	-	
A-48					-	-	-	
A	<b>Total Base Bid Items Amount (Sum of Extended Amounts for each Base Bid Line Item) in Figures: (I.E. 1,727,850.00)</b>						\$	
	<b>Total Base Bid Items Amount (Sum of Extended Amounts for each Base Bid Line Item) in Writing:</b>							
<b>I.E. One Million Seven Hundred Twenty-Seven Thousand Eight Hundred Fifty Dollars and No Cents</b>								

Item No.	SDT No.	Section	Item Description	Unit	Estimated Quantity	Unit Price	Extended Amount	
<b>Allowances in Base Bid per Section 01 23 10 "Alternates and Allowances"</b>								
D-01					-	-	-	
D-02					-	-	-	
D-03					-	-	-	
D-04					-	-	-	
D-05					-	-	-	
D		<b>Total Allowance Amount (Sum of Extended Amounts for Each Allowance Line Item)</b>						\$ -
E		<b>Total Base Bid with Allowances (Sum of C and D) in Figures:</b>						\$ -
		<b>Total Base Bid Items with Allowances (Sum of C and D) in Writing:</b>						
<b>Extra Work in Base Bid per Section 01 29 01 "Measurement and Basis for Payment"</b>								
F-01					-	-	-	
F-02					-	-	-	
F-03					-	-	-	
F-04					-	-	-	
F-05					-	-	-	
G		<b>Total Allowance Amount (Sum of Extended Amounts for Each Allowance Line Item)</b>						\$ -
H		<b>Total Base Bid with Allowances and Extra Work Items(Sum of E and G) in Figures:</b>						\$ -
		<b>Total Base Bid with Allowances and Extra Work (Sum of E and G) in Writing:</b>						
<b>Alternates to be considered for inclusion in the Contract per Section 01 23 10 "Alternates and Allowances"</b>								
I-01					-	-	-	
I-02					-	-	-	
I-03					-	-	-	
J		<b>Total Amount for Alternates for Consideration (Sum of Extended Amounts for Each Alternate Line Item)</b>						\$ -
K		<b>Total Base Bid with Allowance and Alternates for Consideration (Sum of E and J) in Figures:</b>						\$ -
		<b>Total Base Bid with Allowances and Alternates For Consideration (Sum of E and J) in Writing:</b>						

<b>BID SUBMITTED BY:</b>	
Offeror:	_____
Signature:	_____
Printed Name:	_____
Title:	_____
Date:	_____

**ATTACHMENT C**  
**MINIMUM INSURANCE REQUIREMENTS**

**1. Definitions**

“Contractor” means the firm awarded this contract. “FAST” means the Fayetteville Area System of Transit. “City” means the City of Fayetteville, North Carolina. “Contract” means the agreement to which this Attachment is incorporated.

**2. General Terms**

Contractor shall secure and maintain at its own expense each type of insurance specified in this Attachment, with the minimum coverage limits stated. Insurance shall be secured prior to performing any work and maintained throughout the term of the Contract. Any insurance carried by Contractor is primary insurance. If any portion of Contractor’s obligations are subcontracted, Contractor shall require each subcontractor to maintain insurance satisfying these requirements or Contractor may secure and maintain coverage on the subcontractor’s behalf.

**3. Commercial General Liability**

Contractor shall maintain Commercial General Liability Insurance with: (a) combined single limits of \$1,000,000.00 per occurrence; (b) \$2,000,000.00 general aggregate; and (c) \$2,000,000.00 aggregate for products/completed operations. The policy shall include contractual liability coverage and shall designate the City of Fayetteville as an additional insured.

**4. Workers’ Compensation and Employer’s Liability**

If the Contractor employs three (3) or more employees, Contractor shall maintain Workers’ Compensation Insurance as required by North Carolina law, Coverage A (Statutory — State of NC), and Coverage B (Employer’s Liability) with limits of \$500,000 per accident and \$500,000 per policy limit, including occupational disease coverage of \$500,000 per employee.

**5. Automobile Liability**

Contractor shall maintain Commercial Automobile Liability Insurance with limits of not less than \$1,000,000.00 combined single limit per accident covering bodily injury and property damage for owned, non-owned, and hired automobiles.

**6. Other Requirements**

- **Qualified Insurers:** Insurance shall be underwritten by a company authorized to do business in NC by the NC Department of Insurance with an A.M. Best rating of A or better.
- **Additional Insured:** Commercial General Liability and Automobile Liability policies shall name the City of Fayetteville and FAST as additional insureds.
- **Notice of Cancellation:** Each policy shall provide not less than thirty (30) days’ written notice prior to cancellation.
- **Certificates of Insurance:** Before commencing work, Contractor shall furnish a Certificate of Insurance (COI) to the City demonstrating coverage. COI shall state effective and expiration dates, list the City of Fayetteville as additional insured, and note notification provisions.

**ATTACHMENT D**

**E-VERIFY EMPLOYER COMPLIANCE STATEMENT**

E-Verify for Public Contracts: N.C. Gen. Stat. § 64-26; HB 786 (S.L. 2013-418)

The legislation referenced above prohibits governmental units from awarding or entering into contracts unless the contractor and the contractor’s subcontractors comply with the E-Verify requirements of Article 2 of Chapter 64 of the NC General Statutes.

Contractor, hereafter Employer, understands that E-Verify is a federal program operated by the United States Department of Homeland Security and other federal agencies used to verify the work authorization of newly hired employees pursuant to federal law. Employer is defined as: Any person, business entity, or other organization that transacts business in this State and that employs 25 or more employees in this State. **NOTE: This statute does not include State agencies, counties, municipalities, or other governmental bodies.**

Employer understands that Employers, as Defined Herein, Must Use E-Verify. Each employer, after hiring an employee to work in the United States, shall verify the work authorization of the employee through E-Verify in accordance with N.C. Gen. Stat. § 64-26(a).

**Therefore, all employers must be in compliance with the E-Verify requirements to enter into contracts with the City of Fayetteville / FAST.**

**Check the type of employer and complete the information:**

- Employer with fewer than 25 employees** — not required to use E-Verify, but acknowledges this exemption may change.
- Employer with 25 or more employees** — currently enrolled and using E-Verify.

**E-Verify Company ID Number:** \_\_\_\_\_

**Date of Enrollment in E-Verify:** \_\_\_\_\_

**Employer’s Certification:** I hereby certify that the above information is accurate and that this employer will comply with the requirements of Article 2, Chapter 64 of the North Carolina General Statutes and will ensure that any subcontractors hired comply with E-Verify requirements.

Authorized Signature: \_\_\_\_\_ Date: \_\_\_\_\_

Print Name: \_\_\_\_\_ Title: \_\_\_\_\_

Company Name: \_\_\_\_\_

**ATTACHMENT E**

**CONTRACTOR'S STATEMENT OF SALES / USE TAX**

North Carolina General Statute § 105-164.14(c) authorizes a refund of sales and use taxes paid by governmental entities on tangible personal property. In connection with this contract, Contractor must provide a sales tax affidavit with each Application for Payment, beginning with the first application, certifying the total cost of materials and North Carolina Sales Tax paid on materials included in the application. If an application does not include taxable items, the certificate must still be submitted certifying that fact.

For the period of this Application for Payment (or as of the date of this Statement), the undersigned certifies:

**Materials with Sales Tax:** Total cost of materials subject to NC Sales Tax: \$\_\_\_\_\_. NC Sales Tax paid thereon: \$\_\_\_\_\_. Supporting documentation attached.

**No Taxable Items:** This application does not include any materials subject to NC Sales Tax.

Authorized Signature: \_\_\_\_\_ Date: \_\_\_\_\_

Print Name / Title: \_\_\_\_\_

Company: \_\_\_\_\_

**ATTACHMENT F**

**IRAN DIVESTMENT ACT CERTIFICATE**

Pursuant to N.C. Gen. Stat. §§ 147-86.55 through 147-86.61, the Contractor certifies that: (i) it is not identified on the Final Divestment List or any other list of prohibited investments created by the NC State Treasurer pursuant to N.C. Gen. Stat. § 147-86.58; (ii) it has not been designated by the NC State Treasurer pursuant to N.C. Gen. Stat. § 147-86.81 as a company with an investment in Iran; and (iii) it will not take any action causing it to appear on the Treasurer’s Final Divestment List during the term of this agreement.

By signing this Agreement, Contractor further agrees to reimburse the City for any and all damages, costs and attorneys’ fees incurred by the City in connection with any claim that this Agreement or any part thereof is void due to Contractor’s noncompliance with this certification at any time before or during the term of this Agreement.

Authorized Signature: \_\_\_\_\_ Date: \_\_\_\_\_

Print Name / Title: \_\_\_\_\_

Company:

\_\_\_\_\_

**ATTACHMENT G**

**COMPANIES BOYCOTTING ISRAEL DIVESTMENT ACT CERTIFICATION**

Pursuant to N.C. Gen. Stat. §§ 147-86.80 through 147-86.82 (enacted by Session Law 2017-193), the Contractor certifies that: (i) it has not been designated by the NC State Treasurer pursuant to N.C. Gen. Stat. § 147-86.81 as a company engaged in the boycott of Israel; and (ii) it will not take any action causing it to be designated as boycotting Israel during the term of this Agreement.

By signing, Contractor agrees to reimburse the City for any and all damages, costs and attorneys' fees incurred in connection with any claim that this Agreement is void due to Contractor's noncompliance with this certification.

Authorized Signature: \_\_\_\_\_ Date: \_\_\_\_\_

Print Name / Title: \_\_\_\_\_ Company: \_\_\_\_\_

\_\_\_\_\_

**ATTACHMENT H**

**CERTIFICATION REGARDING CONFLICT OF INTEREST**

The Submitter is required to certify that performance of the work will not create any conflict of interest, or to disclose any actual or potential conflicts of interest, by completing and signing ONE of the following statements:

**OPTION 1 — No Conflict of Interest:**

The Submitter hereby certifies that, to the best of its knowledge and belief, performance of the services described in the Scope of Work will not create any conflict of interest for the Submitter, any affiliates, any proposed subcontractors, and key personnel of any of these organizations.

Authorized Signature: \_\_\_\_\_ Date: \_\_\_\_\_

Title: \_\_\_\_\_ Company: \_\_\_\_\_

**OPTION 2 — Disclosure of Conflict of Interest:**

The Submitter hereby discloses the following circumstances that could give rise to a conflict of interest for the Submitter, any affiliates, any proposed subcontractors, and key personnel:

Name of Individual/Company to which potential conflict applies:  
\_\_\_\_\_

Nature of potential conflict: \_\_\_\_\_

Proposed Remedy: \_\_\_\_\_

Authorized Signature: \_\_\_\_\_ Date: \_\_\_\_\_

Title: \_\_\_\_\_ Company: \_\_\_\_\_

**ATTACHMENT I**

**PROPOSER STATEMENT OF NON-COLLUSION**

**BY SUBMISSION OF THIS BID, PROPOSER AND EACH PERSON SIGNING ON BEHALF OF PROPOSER CERTIFIES AS TO ITS OWN ORGANIZATION, UNDER PENALTY OF PERJURY, THAT TO THE BEST OF HIS/HER KNOWLEDGE AND BELIEF:**

1. The prices in this Bid have been arrived at independently, without collusion, consultation, communication, or agreement with any other Proposer or competitor, for the purpose of restricting competition or as to any matter relating to price.
2. Unless otherwise required by law, the prices quoted in this Bid have not been knowingly disclosed and will not be disclosed by Proposer, directly or indirectly, to any other Proposer or competitor before proposals are opened.
3. No attempt has been made or will be made by Proposer to induce any other person, partnership, or corporation to submit or not to submit a bid on any portion of the Project work.

Subscribed to under penalty of perjury under the laws of the State of North Carolina, this \_\_\_\_\_ day of \_\_\_\_\_, 20\_\_.

Name (Print): \_\_\_\_\_ Title: \_\_\_\_\_

Signature: \_\_\_\_\_ Company: \_\_\_\_\_

Date: \_\_\_\_\_

**ATTACHMENT J**  
**DAVIS-BACON PREVAILING WAGE REQUIREMENTS**  
**Applicable Wage Determination**

<b>Wage Determination Number:</b>	General Decision Number: NC20260090
<b>Effective Date:</b>	05/18/26
<b>County:</b>	Cumberland County, North Carolina
<b>Work Classification:</b>	Highway
<b>Source:</b>	SAM.gov — <a href="https://sam.gov">https://sam.gov</a>

**Legal Basis:** The Davis-Bacon Act (40 U.S.C. §§ 3141 et seq.) applies to this contract because it is funded with Federal financial assistance from the Federal Transit Administration (FTA) exceeding \$2,000. All laborers and mechanics employed on work under this contract by the Contractor or any subcontractor shall be paid unconditionally and not less often than once a week wages at rates not less than those established in the current applicable wage determination.

**Contractor Responsibilities:**

- Post the applicable wage determination at the work site in a prominent and accessible location where it can be easily seen by workers;
- Pay all laborers and mechanics at least weekly;
- Submit weekly Certified Payrolls to the City on U.S. Department of Labor Form WH-347 or equivalent with each Application for Payment;
- Maintain payroll records for at least three (3) years after project completion;
- Include Davis-Bacon requirements in all subcontracts; and
- Make payroll records available for inspection upon request by the City, FTA, or U.S. Department of Labor.

"General Decision Number: NC20260090 05/18/2026

State: North Carolina

Construction Types: Highway

Counties: North Carolina Counties of  
 Brunswick, Cumberland, Currituck,  
 Edgecombe, Franklin, Greene, Hoke,  
 Johnston, Nash, New Hanover, Onslow,  
 Pender, Pitt, Wake and Wayne

Modification Number	Publication Date
0	01/02/2026
1	05/18/2026

SUNC2014-005 11/17/2014

	Rates	Fringes		
TRUCK DRIVER (GVWR OF 26,001 LBS OR GREATER).....	\$ 12.37		0.00	
TRUCK DRIVER (GVWR OF 26,000 OR LESS).....	\$ 11.12		0.00	
POWER EQUIPMENT OPERATOR: MILLING MACHINE.....	\$ 15.36		0.00	
POWER EQUIPMENT OPERATOR: MECHANIC.....	\$ 17.55		0.00	
POWER EQUIPMENT OPERATOR (TACK TRUCK/DISTRIBUTOR OPERATOR).....	\$ 14.52	0.00		
POWER EQUIPMENT OPERATOR (SLIP FORM MACHINE).....	\$ 16.50		0.00	
POWER EQUIPMENT OPERATOR (SCRAPER ROUGH).....	\$ 11.35		0.00	
POWER EQUIPMENT OPERATOR (SCRAPER FINISH).....	\$ 12.71		0.00	
POWER EQUIPMENT OPERATOR (ROLLER OTHER).....	\$ 11.36		0.00	
POWER EQUIPMENT OPERATOR (ROLLER ASPHALT FINISH)....	\$ 13.85		0.00	
POWER EQUIPMENT OPERATOR (ROLLER ASPHALT BREAKDOWN).\$	12.45		0.00	0.00
POWER EQUIPMENT OPERATOR (PAVER CONCRETE).....	\$ 18.20		0.00	
POWER EQUIPMENT OPERATOR (PAVER ASPHALT).....	\$ 15.59		0.00	
POWER EQUIPMENT OPERATOR (PAVEMENT MARKING EQUIPMENT).....	\$ 12.11	0.00		
POWER EQUIPMENT OPERATOR (OILER/GREASER).....	\$ 13.55		0.00	
POWER EQUIPMENT OPERATOR (OFF-ROAD HAULER/WATER TANKER).....	\$ 11.36	0.00		
POWER EQUIPMENT OPERATOR (MATERIAL TRANSFER VEHICLE (SHUTTLE BUGGY)).....	\$ 15.18	0.00		
POWER EQUIPMENT OPERATOR (LOADER GREATER THAN 2 CUBIC YARDS).....	\$ 14.14	0.00		
POWER EQUIPMENT OPERATOR (LOADER 2 CUBIC YARDS OR LESS).....	\$ 13.76	0.00		

POWER EQUIPMENT OPERATOR (GRADER/BLADE ROUGH).....	\$ 14.62	0.00
POWER EQUIPMENT OPERATOR (GRADER/BLADE FINE).....	\$ 18.47	0.00
POWER EQUIPMENT OPERATOR (EXCAVATOR ROUGH).....	\$ 14.00	0.00
POWER EQUIPMENT OPERATOR (EXCAVATOR FINE).....	\$ 16.60	0.00
POWER EQUIPMENT OPERATOR (DRILL OPERATOR STRUCTURE).	\$ 21.14	0.00
POWER EQUIPMENT OPERATOR (DRILL OPERATOR ROCK).....	\$ 14.38	0.00
POWER EQUIPMENT OPERATOR (CRANE ROUGH/ALL TERRAIN)..	\$ 20.67	0.00
POWER EQUIPMENT OPERATOR (CRANE OTHER).....	\$ 20.08	0.00
POWER EQUIPMENT OPERATOR (CRANE BOOM TRUCKS).....	\$ 20.54	0.00
POWER EQUIPMENT OPERATOR (CONCRETE GRINDER/GROOVER).	\$ 20.34	2.30
POWER EQUIPMENT OPERATOR (BULLDOZER ROUGH).....	\$ 14.34	0.00
POWER EQUIPMENT OPERATOR (BULLDOZER FINE).....	\$ 17.04	0.00
POWER EQUIPMENT OPERATOR (ASPHALT BROOM TRACTOR)....	\$ 11.85	0.00
PAINTER (BRIDGE).....	\$ 24.57	0.00
LABORER: PIPELAYER.....	\$ 12.17	0.00
LABORER: COMMON OR GENERAL.....	\$ 10.20	0.00
LABORER (TRAFFIC SIGNAL/LIGHTING INSTALLER).....	\$ 14.89	0.00
LABORER (GUARDRAIL/FENCE INSTALLER).....	\$ 12.87	0.00
LABORER (CEMENT MASON/CONCRETE FINISHER TENDER)....	\$ 12.54	0.00
LABORER (CARPENTER TENDER).....	\$ 12.88	0.00
LABORER (ASPHALT SCREED/JACKMAN).....	\$ 14.33	0.00
LABORER (ASPHALT RAKER AND SPREADER).....	\$ 12.46	0.00
IRONWORKER.....	\$ 16.02	0.00
ELECTRICIAN (TELECOMMUNICATIONS TECHNICIAN).....	\$ 16.79	0.63
ELECTRICIAN (ELECTRICIAN).....	\$ 17.97	0.00
CEMENT MASON/CONCRETE FINISHER.....	\$ 14.48	0.00
CARPENTER.....	\$ 13.72	0.00
BLASTER.....	\$ 21.04	0.00

-----  
WELDERS - Receive rate prescribed for craft performing operation to which welding is incidental.  
=====

Note: Executive Order (EO) 13706, Establishing Paid Sick Leave for Federal Contractors applies to all contracts subject to the Davis-Bacon Act for which the contract is awarded (and any solicitation was issued) on or after January 1, 2017. If this contract is covered by the EO, the contractor must provide employees with 1 hour of paid sick leave for every 30 hours they work, up to 56 hours of paid sick leave each year. Employees must be permitted to use paid sick leave for their own illness, injury or other health-related needs, including preventive care; to assist a family member (or person who is like family to the employee) who is ill, injured, or has other health-related needs, including preventive care; or for reasons resulting from, or to assist a family member (or person who is like family to the employee) who is a victim of, domestic violence, sexual assault, or stalking. Additional information on contractor requirements and worker protections under the EO is available at <https://www.dol.gov/agencies/whd/government-contracts>.

Note: Executive Order 13658 generally applies to contracts subject

to the Davis-Bacon Act that were awarded on or between January 1, 2015 and January 29, 2022, and that have not been renewed or extended on or after January 30, 2022. Executive Order 13658 does not apply to contracts subject only to the Davis-Bacon Related Acts regardless of when they were awarded. If a contract is subject to Executive Order 13658, the contractor must pay all covered workers at least \$13.65 per hour (or the applicable wage rate listed on this wage determination, if it is higher) for all hours spent performing on the contract from May 11, 2026, through December 31, 2026. The applicable Executive Order minimum wage rate will be adjusted annually. Additional information on contractor requirements and worker protections under Executive Order 13658 is available at [www.dol.gov/whd/govcontracts](http://www.dol.gov/whd/govcontracts).

Unlisted classifications needed for work not included within the scope of the classifications listed may be added after award only as provided in the labor standards contract clauses (29CFR 5.5 (a) (1) (iii)).

---

The body of each wage determination lists the classifications and wage rates that have been found to be prevailing for the type(s) of construction and geographic area covered by the wage determination. The classifications are listed in alphabetical order under rate identifiers indicating whether the particular rate is a union rate (current union negotiated rate), a survey rate, a weighted union average rate, a state adopted rate, or a supplemental classification rate.

#### Union Rate Identifiers

A four-letter identifier beginning with characters other than SU , UAVG , SA , or SC denotes that a union rate was prevailing for that classification in the survey. Example: PLUM0198-005 07/01/2024. PLUM is an identifier of the union whose collectively bargained rate prevailed in the survey for this classification, which in this example would be Plumbers. 0198 indicates the local union number or district council number where applicable, i.e., Plumbers Local 0198. The next number, 005 in the example, is an internal number used in processing the wage determination. The date, 07/01/2024 in the example, is the effective date of the most current negotiated rate.

Union prevailing wage rates are updated to reflect all changes over time that are reported to WHD in the rates in the collective bargaining agreement (CBA) governing the classification.

#### Union Average Rate Identifiers

The UAVG identifier indicates that no single rate prevailed for those classifications, but that 100% of the data reported for the classifications reflected union rates. EXAMPLE: UAVG-OH-0010 01/01/2024. UAVG indicates that the rate is a

weighted union average rate. OH indicates the State of Ohio. The next number, 0010 in the example, is an internal number used in producing the wage determination. The date, 01/01/2024 in the example, indicates the date the wage determination was updated to reflect the most current union average rate.

A UAVG rate will be updated once a year, usually in January, to reflect a weighted average of the current rates in the collective bargaining agreements on which the rate is based.

### Survey Rate Identifiers

The SU identifier indicates that either a single non-union rate prevailed (as defined in 29 CFR 1.2) for this classification in the survey or that the rate was derived by computing a weighted average rate based on all the rates reported in the survey for that classification. As a weighted average rate includes all rates reported in the survey, it may include both union and non-union rates. Example: SUFL2022-007 6/27/2024. SU indicates the rate is a single non-union prevailing rate or a weighted average of survey data for that classification. FL indicates the State of Florida. 2022 is the year of the survey on which these classifications and rates are based. The next number, 007 in the example, is an internal number used in producing the wage determination. The date, 6/27/2024 in the example, indicates the survey completion date for the classifications and rates under that identifier.

SU wage rates typically remain in effect until a new survey is conducted. However, the Wage and Hour Division (WHD) has the discretion to update such rates under 29 CFR 1.6(c)(1).

### State Adopted Rate Identifiers

The SA identifier indicates that the classifications and prevailing wage rates set by a state (or local) government were adopted under 29 C.F.R 1.3(g)-(h). Example: SAME2023-007 01/03/2024. SA reflects that the rates are state adopted. ME refers to the State of Maine. 2023 is the year during which the state completed the survey on which the listed classifications and rates are based. The next number, 007 in the example, is an internal number used in producing the wage determination. The date, 01/03/2024 in the example, reflects the date on which the classifications and rates under the SA identifier took effect under state law in the state from which the rates were adopted.

---

### WAGE DETERMINATION APPEALS PROCESS

1) Has there been an initial decision in the matter? This can be:

- a) a survey underlying a wage determination
- b) an existing published wage determination
- c) an initial WHD letter setting forth a position on a wage determination matter

d) an initial conformance (additional classification and rate) determination

On survey related matters, initial contact, including requests for summaries of surveys, should be directed to the WHD Branch of Wage Surveys. Requests can be submitted via email to [davisbaconinfo@dol.gov](mailto:davisbaconinfo@dol.gov) or by mail to:

Branch of Wage Surveys  
Wage and Hour Division  
U.S. Department of Labor  
200 Constitution Avenue, N.W.  
Washington, DC 20210

Regarding any other wage determination matter such as conformance decisions, requests for initial decisions should be directed to the WHD Branch of Construction Wage Determinations. Requests can be submitted via email to [BCWD-Office@dol.gov](mailto:BCWD-Office@dol.gov) or by mail to:

Branch of Construction Wage Determinations  
Wage and Hour Division  
U.S. Department of Labor  
200 Constitution Avenue, N.W.  
Washington, DC 20210

2) If an initial decision has been issued, then any interested party (those affected by the action) that disagrees with the decision can request review and reconsideration from the Wage and Hour Administrator (See 29 CFR Part 1.8 and 29 CFR Part 7). Requests for review and reconsideration can be submitted via email to [dba.reconsideration@dol.gov](mailto:dba.reconsideration@dol.gov) or by mail to:

Wage and Hour Administrator  
U.S. Department of Labor  
200 Constitution Avenue, N.W.  
Washington, DC 20210

The request should be accompanied by a full statement of the interested party's position and any information (wage payment data, project description, area practice material, etc.) that the requestor considers relevant to the issue.

3) If the decision of the Administrator is not favorable, an interested party may appeal directly to the Administrative Review Board (formerly the Wage Appeals Board). Write to:

Administrative Review Board  
U.S. Department of Labor  
200 Constitution Avenue, N.W.  
Washington, DC 20210.

---

END OF GENERAL DECISION

"

# Davis-Bacon and Related Acts Weekly Certified Payroll Form

(For Contractor's Optional Use; See Instructions at [www.dol.gov/whd/forms/wh347instr.htm](http://www.dol.gov/whd/forms/wh347instr.htm))



Unless otherwise noted, the information requested is specific to the named project below.  
Persons are not required to respond to the collection of information unless it displays a currently valid OMB control number.

Rev. January 2025  
OMB No.: 1235-0008  
Expires: 01/31/2028

SUBMISSION OF FINAL DBRA CERTIFIED PAYROLL FORM

PRIME CONTRACTOR

SUBCONTRACTOR

PROJECT NAME				PROJECT NO. or CONTRACT NO.			CERTIFIED PAYROLL NO.		PRIME CONTRACTOR'S/SUBCONTRACTOR'S BUSINESS NAME													
PROJECT LOCATION				WAGE DETERMINATION NO.			WEEK ENDING DATE		PRIME CONTRACTOR'S/SUBCONTRACTOR'S BUSINESS ADDRESS													
(1A)	(1B)	(1C)	(1D)	(1E)	(2)	(3)	(4)				(5)	(6A)	(6B)	(6C)	(7A)	(7B)	(8)			(9)		
WORKER ENTRY NO.	WORKER LAST NAME	WORKER FIRST NAME	WORKER MIDDLE INITIAL	WORKER IDENTIFYING NO.	(J) JOURNEYWORKER (RA) REGISTERED APPRENTICE	LABOR CLASSIFICATION	ST = STRAIGHT TIME OT = OVERTIME	(TOP) DAYS OF WORK WEEK (BOTTOM) DATES				TOTAL HOURS WORKED FOR WEEK	HOURLY WAGE RATE PAID FOR ST AND OT	TOTAL FRINGE BENEFIT CREDIT	PAYMENT IN LIEU OF FRINGE BENEFITS	GROSS AMT EARNED	GROSS AMT EARNED FOR ALL WORK	DEDUCTIONS FOR ALL WORK			NET PAY TO WORKER FOR ALL WORK	
																		TAX WITH-HOLDINGS	FICA	OTHER (MUST SPECIFY, SEE INSTRUCTIONS)		TOTAL DEDUCTIONS
								HOURS WORKED EACH DAY														
							ST															
							OT															
							ST															
							OT															
							ST															
							OT															
							ST															
							OT															
							ST															
							OT															
							ST															
							OT															
							ST															
							OT															

While use of Form WH-347 itself is optional, covered contractors and subcontractors performing work on Federal or federally assisted construction contracts are required by the DBRA regulations and the contract clauses to submit payroll information on a weekly basis. The Copeland Act (40 U.S.C. § 3145) requires contractors and subcontractors performing work on Federal or federally financed construction contracts to, on a weekly basis, "furnish a statement on the wages paid each employee during the prior week." U.S. Department of Labor (DOL) Regulations at 29 C.F.R. § 5.5(a)(3)(ii) require contractors and subcontractors to submit weekly certified payrolls to the appropriate Federal agency if the agency is a party to the contract (or, if the agency is not such a party, to the applicant, sponsor, owner, or other entity, as the case may be, that maintains such records, for transmission to the Federal agency). Each certified payroll must be accompanied by a signed "Statement of Compliance" (e.g., page 2 of the WH-347 or another document with identical wording) indicating that the certified payrolls are accurate and complete, and that each laborer or mechanic has been paid not less than the required Davis-Bacon prevailing wage rate(s) (including any fringe benefits) for the work performed. DOL and contracting agencies receiving this information review the information to determine whether workers have received legally required wages and fringe benefits.

**Public Burden Statement**

We estimate that it will take an average of 55 minutes to complete this collection, including time for reviewing instructions, searching existing data sources, gathering and maintaining the data needed, and completing and reviewing the collection of information. If you have any comments regarding these estimates or any other aspect of this collection, including suggestions for reducing this burden, send them to the Administrator, Wage and Hour Division, U.S. Department of Labor, Room S3502, 200 Constitution Avenue, N.W. Washington, D.C. 20210 (over)

PROJECT NAME	PROJECT NO. or CONTRACT NO.	PAYROLL NO.	PRIME CONTRACTOR'S/SUBCONTRACTOR'S BUSINESS NAME
PROJECT LOCATION	WEEK ENDING DATE	CERTIFYING OFFICIAL'S NAME AND TITLE	

I paid or supervised the payment of the laborers or mechanics working on the above project during the stated time period. I certify the following:

- The payroll information submitted with this statement is correct and complete for the above project during the above period, and the wage and fringe benefit rates paid to the workers, including credit taken for the reasonably anticipated costs of a bona fide fringe benefit plan, fund or program, are not less than the applicable wage and fringe benefits rates for the classification(s) of work actually performed, as specified in the wage determination(s) incorporated into the contract.
- All regular payrolls and all other basic records that the contractor is required to maintain for this payroll period are complete and accurate and will be made available upon request from the agency or the Department of Labor.
- The classifications reported for each laborer or mechanic are the classification(s) of work that each worker actually performed.
- Any workers paid as apprentices during the above period are duly registered in a bona fide apprenticeship program registered with the Office of Apprenticeship, Employment and Training Administration, United States Department of Labor ("OA"), or a State Apprenticeship Agency ("SAA") recognized by Department of Labor. I have verified the registered apprenticeship program information provided below as accurate and applicable to any apprentices identified on page 1 of this form.

APPRENTICESHIP PROGRAM NAME	REGISTERED	NAME OF LABOR CLASSIFICATION
	<input type="checkbox"/> OA <input type="checkbox"/> SAA	
	<input type="checkbox"/> OA <input type="checkbox"/> SAA	
	<input type="checkbox"/> OA <input type="checkbox"/> SAA	

- Fringe benefits have been paid in cash and/or to bona fide fringe benefit plans, funds, or programs. Where the contractor is claiming an hourly credit for their contributions to or reasonably anticipated costs of a bona fide fringe benefit plan, fund, or program, provide plan information and the hourly credit claimed for each worker listed on the previous page of this form.

**HOURLY CREDIT FOR FRINGE BENEFITS**

*If an amount is listed in (6B) on the first page of this certified payroll form, enter the hourly credit claimed under each plan name, type and number for each worker and check whether the plan is funded or unfunded.*

NAME OF WORKER	FB NAME		FB NAME		FB NAME		FB NAME		FB NAME		FB NAME		TOTAL HOURLY CREDIT
	FB TYPE		FB TYPE		FB TYPE		FB TYPE		FB TYPE		FB TYPE		
	PLAN NO.		PLAN NO.		PLAN NO.		PLAN NO.		PLAN NO.		PLAN NO.		
	<input type="checkbox"/> Funded <input type="checkbox"/> Unfunded		<input type="checkbox"/> Funded <input type="checkbox"/> Unfunded		<input type="checkbox"/> Funded <input type="checkbox"/> Unfunded		<input type="checkbox"/> Funded <input type="checkbox"/> Unfunded		<input type="checkbox"/> Funded <input type="checkbox"/> Unfunded		<input type="checkbox"/> Funded <input type="checkbox"/> Unfunded		
	Hourly Credit	\$	Hourly Credit	\$	Hourly Credit	\$	Hourly Credit	\$	Hourly Credit	\$	Hourly Credit	\$	\$
	Hourly Credit	\$	Hourly Credit	\$	Hourly Credit	\$	Hourly Credit	\$	Hourly Credit	\$	Hourly Credit	\$	\$
	Hourly Credit	\$	Hourly Credit	\$	Hourly Credit	\$	Hourly Credit	\$	Hourly Credit	\$	Hourly Credit	\$	\$
	Hourly Credit	\$	Hourly Credit	\$	Hourly Credit	\$	Hourly Credit	\$	Hourly Credit	\$	Hourly Credit	\$	\$
	Hourly Credit	\$	Hourly Credit	\$	Hourly Credit	\$	Hourly Credit	\$	Hourly Credit	\$	Hourly Credit	\$	\$
	Hourly Credit	\$	Hourly Credit	\$	Hourly Credit	\$	Hourly Credit	\$	Hourly Credit	\$	Hourly Credit	\$	\$
	Hourly Credit	\$	Hourly Credit	\$	Hourly Credit	\$	Hourly Credit	\$	Hourly Credit	\$	Hourly Credit	\$	\$

- All workers on the project have been paid the full weekly wages earned, and no rebates or deductions have been or will be made either directly or indirectly, other than permissible deductions as defined in 29 CFR part 3.

ADDITIONAL REMARKS

SIGNATURE OF CERTIFYING OFFICIAL	DATE	TELEPHONE NUMBER	EMAIL ADDRESS
		(____) ____ - ____	

THE WILLFUL FALSIFICATION OF ANY OF THE ABOVE STATEMENTS MAY SUBJECT THE CONTRACTOR OR SUBCONTRACTOR TO CIVIL OR CRIMINAL PROSECUTION (SEE SECTION 1001 OF TITLE 18 AND SECTION 3729 OF TITLE 31 OF THE UNITED STATES CODE), AS WELL AS DEBARMENT FROM FUTURE FEDERAL AND FEDERALLY-ASSISTED CONTRACTS. INFORMATION REPORTED IN CERTIFIED PAYROLLS MAY BE SUBJECT TO DISCLOSURE IN RESPONSE TO A FREEDOM OF INFORMATION ACT REQUEST.

**ATTACHMENT K**

**SMALL AND DISADVANTAGED BUSINESS ENTERPRISE (SDBE/M/WBE) FORMS**

**City of Fayetteville SDBE Program**

**DBE Requirements — FTA-Funded Contract**

**Current Status of DBE Goals on Construction Contracts:** Consistent with the U.S. Department of Transportation Interim Final Rule effective October 3, 2025 (Docket No. DOT-OST-2025-0897), which eliminated race- and gender-based presumptions of social and economic disadvantage from the federal DBE program, NCDOT has issued guidance providing that contract-specific DBE goals shall not be set on construction contracts during the reevaluation transition period. Accordingly, **no contract-specific federal DBE goal is established for this project.** Contractor shall apply race-neutral measures to facilitate participation by eligible firms during the transition period. Contractor shall verify current FTA and NCDOT guidance at the time of bid.

**City of Fayetteville SDBE Program**

The City of Fayetteville aspires to spend **40%** of its eligible contract dollars with small local suppliers and contractors located in Cumberland and Hoke Counties, pursuant to the City’s Charter as amended by H.B. 198. Contractor shall make good faith efforts to utilize certified SDBE firms.

**SDBE Goal for This Contract: 0%**

**SDBE Utilization Plan**

Contractor shall complete and submit the SDBE Utilization Plan below identifying each SDBE firm it intends to utilize, the type of work, and the estimated dollar amount:

<b>SDBE Firm Name</b>	<b>Type of Work</b>	<b>Dollar Amount</b>	<b>% of Contract</b>

Contractor Signature: \_\_\_\_\_ Date: \_\_\_\_\_

Print Name / Title: \_\_\_\_\_

Company: \_\_\_\_\_

**SDBE Reporting Obligation:** Contractor shall submit SDBE utilization reports with each monthly Application for Payment documenting actual payments made to SDBE subcontractors. Failure to comply with SDBE requirements may result in withholding of progress payments, suspension or termination of the Contract, or debarment from future City contracts.

**ATTACHMENT L**

**CERTIFICATION AND RESTRICTIONS ON LOBBYING**

**31 U.S.C. § 1352 (Byrd Anti-Lobbying Amendment)**

**NOTE:** The statutory threshold for the Byrd Anti-Lobbying certification requirement is contracts or agreements exceeding \$100,000 (31 U.S.C. § 1352; 2 CFR Part 200, Appendix II). The estimated value of this contract is \$50,000. This certification is therefore included as a best practice measure consistent with FTA procurement integrity standards, but is not a legal requirement at this contract value. It is nonetheless required as part of this bid package as a matter of City procurement policy.

**I hereby certify on behalf of:**

(Name of Bidder / Company Name) \_\_\_\_\_

- No federal appropriated funds have been paid or will be paid, by or on behalf of the undersigned, to any person for influencing or attempting to influence an officer or employee of any agency, a Member of Congress, an officer or employee of Congress, or an employee of a Member of Congress in connection with the awarding of any federal contract, the making of any federal grant, the making of any federal loan, the entering into of any cooperative agreement, and the extension, continuation, renewal, amendment, or modification of any federal contract, grant, loan, or cooperative agreement.
- If any funds other than federal appropriated funds have been paid or will be paid to any person for influencing or attempting to influence an officer or employee of any agency, a Member of Congress, an officer or employee of Congress, or an employee of a Member of Congress in connection with this federal contract, grant, loan, or cooperative agreement, the undersigned shall complete and submit Standard Form LLL, "Disclosure Form to Report Lobbying," in accordance with its instructions.
- The undersigned shall require that the language of this certification be included in the award documents for all sub-awards at all tiers (including subcontracts) and that all sub-recipients shall certify and disclose accordingly.

Name of Bidder / Company: \_\_\_\_\_

Authorized Signature: \_\_\_\_\_ Date: \_\_\_\_\_

Type or Print Name: \_\_\_\_\_ Title: \_\_\_\_\_

**ATTACHMENT M**

**TERMINATING ILLEGAL DISCRIMINATION CERTIFICATION**

\_\_\_\_\_ certifies that: (i) it does not operate any DEI programs that violate any applicable Federal anti-discrimination laws; (ii) it is compliant in all respects with all applicable Federal anti-discrimination laws material to the government’s payment decisions; and (iii) agrees that, if a violation of this certification is found, it could lead to liability under the False Claims Act.

By signing, Contractor further agrees, as an independent obligation separate and apart from this Agreement, to reimburse the City for any and all damages, costs, and attorneys’ fees incurred by the City in connection with any claim that this Agreement or any part thereof is void due to Contractor’s noncompliance with this certification at any time before or during the term of this Agreement.

Company Name: \_\_\_\_\_

Authorized Signature: \_\_\_\_\_ Date: \_\_\_\_\_

Print Name / Title: \_\_\_\_\_

**ATTACHMENT N**  
**ITB RESPONSE CHECKLIST**

**ALL FORMS AND REQUIRED ITEMS BELOW MUST BE COMPLETED AND INCLUDED WHEN YOU SUBMIT YOUR BID PACKAGE.**

**NOTE ON RESPONSIVENESS:** Failure to submit all required items, particularly the Buy America Certification Form (O-1), Davis-Bacon Wage Rate Acknowledgment (J), and all signed certifications, may render a Bid non-responsive and subject to rejection.

<b>Item</b>	<b>Required Submission Item</b>	<b>YES</b>	<b>NO</b>
<b>1</b>	Attachment A — Bid Form (signed by authorized representative)	<input type="checkbox"/>	<input type="checkbox"/>
<b>2</b>	Attachment B — Bid Price Sheet (all unit prices completed, total provided)	<input type="checkbox"/>	<input type="checkbox"/>
<b>3</b>	Attachment C — Certificate of Insurance / Proof of Insurance	<input type="checkbox"/>	<input type="checkbox"/>
<b>4</b>	Attachment D — E-Verify Affidavit (City of Fayetteville / FAST)	<input type="checkbox"/>	<input type="checkbox"/>
<b>5</b>	Attachment E — Contractor’s Statement of Sales/Use Tax	<input type="checkbox"/>	<input type="checkbox"/>
<b>6</b>	Attachment F — Iran Divestment Act Certificate	<input type="checkbox"/>	<input type="checkbox"/>
<b>7</b>	Attachment G — Companies Boycotting Israel Divestment Act Certification	<input type="checkbox"/>	<input type="checkbox"/>
<b>8</b>	Attachment H — Certificate Regarding Conflict of Interest	<input type="checkbox"/>	<input type="checkbox"/>
<b>9</b>	Attachment I — Non-Collusion Statement	<input type="checkbox"/>	<input type="checkbox"/>
<b>10</b>	Attachment J — Davis-Bacon Wage Rates Acknowledgment (REQUIRED — FTA-funded)	<input type="checkbox"/>	<input type="checkbox"/>
<b>11</b>	Attachment K — SDBE/M/WBE Utilization Plan and Forms	<input type="checkbox"/>	<input type="checkbox"/>
<b>12</b>	Attachment L — Lobbying Certification	<input type="checkbox"/>	<input type="checkbox"/>
<b>13</b>	Attachment M — Terminating Illegal Discrimination Certification	<input type="checkbox"/>	<input type="checkbox"/>
<b>14</b>	Attachment N — This ITB Response Checklist (completed)	<input type="checkbox"/>	<input type="checkbox"/>

<b>15</b>	Attachment O-1 — Buy America Certification Form (REQUIRED — FTA-funded)	<input type="checkbox"/>	<input type="checkbox"/>
<b>16</b>	Copy of valid North Carolina General Contractor License	<input type="checkbox"/>	<input type="checkbox"/>
<b>17</b>	Key Personnel / Project Manager Identification	<input type="checkbox"/>	<input type="checkbox"/>
<b>18</b>	Subcontractor List (name, address, and role for each subcontractor)	<input type="checkbox"/>	<input type="checkbox"/>
<b>19</b>	Project Schedule / Work Plan (75-day project)	<input type="checkbox"/>	<input type="checkbox"/>
<b>20</b>	Addendum Acknowledgment (on Bid Form, Attachment A)	<input type="checkbox"/>	<input type="checkbox"/>

**NOTE:** Attachment O (FTA Requirements) and Exhibits A and B (Drawings and Draft Contract) are incorporated by reference in this ITB and do not require separate submission by Bidders. Bidders are responsible for reviewing these documents before submitting a Bid.

## ATTACHMENT O

### FEDERAL TRANSIT ADMINISTRATION (FTA) REQUIREMENTS

#### Applicable Federal Contract Provisions

**APPLICABILITY NOTICE:** This contract is funded with financial assistance from the Federal Transit Administration (FTA) under 49 U.S.C. Chapter 53 (\$40,000 FTA funds). The federal provisions in this Attachment apply to this contract. Only FTA-specific provisions and cross-cutting requirements applicable to FTA-funded construction contracts are included herein.

#### **1. Disclaimer of Federal Government Obligations or Liability**

The Contractor and any subcontractors acknowledge and agree that, notwithstanding any concurrence by the Federal Government in or approval of the solicitation or award of this contract, absent the express written consent by the Federal Government, the Federal Government is not a party to this contract and shall not be subject to any obligations or liabilities to the Contractor or any other party pertaining to any matter resulting from this contract. It is further agreed that this clause shall be included in each subcontract financed in whole or in part with Federal assistance and shall not be modified, except to identify the subcontractor who will be subject to its provisions.

#### **2. Protest Procedures**

Protests related to this procurement must be addressed to the City of Fayetteville, 433 Hay Street, Fayetteville, NC 28301 and shall be received in writing within **five (5) calendar days** of bid award. Responses will be supplied not later than seven (7) calendar days following receipt of the protest. A protester must exhaust all administrative remedies with the City of Fayetteville before pursuing a protest with the Federal grantor agency (FTA). Reviews of protests by FTA are limited to: (1) violations of federal law or regulations and the standards of this section; and (2) violations of the grantee's protest procedures for failure to review a complaint or protest. Protests received by FTA other than those specified above will be referred to the City of Fayetteville.

#### **3. Access to Records and Reports**

**Authority:** 49 U.S.C. § 5325; 49 C.F.R. § 633.17; 2 C.F.R. § 200.337 (verify current section number in eCFR; the 2024 Uniform Guidance update may have renumbered this provision).

The Contractor agrees to provide the City of Fayetteville / FAST, FTA, the Comptroller General of the United States, and their authorized representatives access to any books, documents, papers, and records of the Contractor which are directly pertinent to this contract, for purposes of making audits, examinations, excerpts, and transcriptions. Contractor also agrees, pursuant to 49 C.F.R. § 633.17, to provide FTA or its authorized representatives access to Contractor's records and construction sites pertaining to this project, which is receiving federal financial assistance through programs described at 49 U.S.C. §§ 5307, 5309, or 5311.

The Contractor agrees to maintain all books, records, accounts, and reports required under this contract for a period of not less than three (3) years after the date of termination or expiration of this contract, except in the event of litigation or settlement of claims arising from performance of this contract, in which case Contractor agrees to maintain records until all such litigation, appeals,

claims, or exceptions have been disposed of. See 2 C.F.R. § 200.334 (verify current section number).

#### **4. Federal Changes**

**Authority:** 2 C.F.R. Part 200

Contractor shall at all times comply with all applicable Federal regulations, policies, procedures, and directives, including without limitation those listed directly or by reference in the FTA Master Agreement between the City of Fayetteville / FAST and FTA, as they may be amended or promulgated from time to time during the term of this contract. Contractor's failure to so comply shall constitute a material breach of this contract.

#### **5. No Government Obligation to Third Parties**

The City of Fayetteville / FAST and Contractor acknowledge and agree that, notwithstanding any concurrence by the Federal Government in or approval of the solicitation or award of the underlying contract, absent the express written consent by the Federal Government, the Federal Government is not a party to this contract and shall not be subject to any obligations or liabilities to the City of Fayetteville / FAST, Contractor, or any other party pertaining to any matter resulting from the underlying contract. The Contractor agrees to include this clause in each subcontract financed in whole or in part with Federal assistance.

#### **6. Program Fraud and False or Fraudulent Statements**

**Authority:** 31 U.S.C. §§ 3801 et seq.; 2 C.F.R. § 200.113; 18 U.S.C. § 1001; 49 U.S.C. § 5307

The Contractor acknowledges that the provisions of the Program Fraud Civil Remedies Act of 1986, as amended, 31 U.S.C. §§ 3801 et seq., and U.S. DOT regulations, "Program Fraud Civil Remedies," 49 C.F.R. Part 31, apply to its actions pertaining to this project. Upon execution of the underlying contract, the Contractor certifies or affirms the truthfulness and accuracy of any statement it has made, it makes, it may make, or causes to be made, pertaining to the underlying contract or the Federal-assisted project. If it makes, or causes to be made, a false, fictitious, or fraudulent claim, statement, submission, or certification, the Federal Government reserves the right to impose the penalties of the Program Fraud Civil Remedies Act on the Contractor.

The Contractor also acknowledges that if it makes, or causes to be made, a false, fictitious, or fraudulent claim, statement, submission, or certification to the Federal Government under a contract connected with a project financed in whole or in part with Federal assistance, the Government reserves the right to impose the penalties of 18 U.S.C. § 1001 and 49 U.S.C. § 5307(n)(1) on the Contractor. The Contractor agrees to include the above two clauses in each subcontract financed in whole or in part with Federal assistance.

#### **7. Civil Rights Requirements**

**Nondiscrimination:** In accordance with Title VI of the Civil Rights Act of 1964, as amended, 42 U.S.C. § 2000d, Section 303 of the Age Discrimination Act of 1975, as amended, 42 U.S.C. § 6102, Section 202 of the Americans with Disabilities Act of 1990, 42 U.S.C. § 12132, and Federal transit law at 49 U.S.C. § 5332, the Contractor agrees that it will not discriminate against any employee or applicant for employment because of race, color, creed, national origin, sex, age, or disability. In addition, the Contractor agrees to comply with applicable Federal implementing regulations and other implementing requirements FTA may issue.

## **Equal Employment Opportunity:**

**(a) Race, Color, Creed, National Origin, Sex, Age:** In accordance with Title VII of the Civil Rights Act, as amended, 42 U.S.C. § 2000e, and Federal transit laws at 49 U.S.C. § 5332, the Contractor agrees to comply with all applicable equal employment opportunity requirements of U.S. Department of Labor regulations, and any applicable Federal statutes, executive orders, regulations, and Federal policies that may affect construction activities undertaken in the course of the Project. The Contractor agrees to take affirmative action to ensure that applicants are employed, and that employees are treated during employment, without regard to their race, color, creed, national origin, sex, age, or disability.

**NOTE:** Executive Order 11246 and Executive Order 11375 were rescinded by Executive Order 14173 on January 21, 2025, effective April 21, 2025. References to those rescinded orders have been removed from this document.

**(b) Age:** In accordance with the Age Discrimination in Employment Act of 1967, as amended, 29 U.S.C. §§ 623, and Federal transit law at 49 U.S.C. § 5332, the Contractor agrees to refrain from discrimination against present and prospective employees for reason of age.

**(c) Disabilities:** In accordance with Section 102 of the Americans with Disabilities Act, as amended, 42 U.S.C. § 12112, the Contractor agrees to comply with the requirements of the U.S. Equal Employment Opportunity Commission, “Regulations to Implement the Equal Employment Provisions of the Americans with Disabilities Act,” 29 C.F.R. Part 1630.

## **8. Disadvantaged Business Enterprise (DBE) Requirements**

**Authority:** 49 C.F.R. Part 26 (as amended by Interim Final Rule effective October 3, 2025, Docket No. DOT-OST-2025-0897)

As of October 3, 2025, the U.S. Department of Transportation issued an Interim Final Rule that substantially modified the DBE program under 49 C.F.R. Part 26. The rule eliminates race- and gender-based presumptions of social and economic disadvantage. In accordance with this rule and NCDOT guidance issued during the transition period, **no contract-specific DBE goal is established for this project.** Race-neutral measures shall be used to facilitate DBE participation.

### **Current DBE Requirements during IFR Transition Period:**

- All applicants for DBE certification must now provide individualized proof of social and economic disadvantage on a case-by-case basis, without regard to race or sex;
- All currently certified DBE firms are subject to mandatory reevaluation and recertification under the new individualized standards through the NC Unified Certification Program (NCUCP);
- Recipients must use race-neutral methods to facilitate DBE participation; and
- To the extent authorized by Federal law, the City of Fayetteville / FAST agrees to facilitate participation by DBEs in this Project.

**Flow-Down:** The Contractor agrees to include these requirements in each subcontract financed in whole or in part with Federal assistance, modified only if necessary to identify the affected parties.

## **9. Energy Conservation Requirements**

**Authority:** 42 U.S.C. §§ 6321 et seq.; 2 C.F.R. Part 200

The Contractor agrees to comply with mandatory standards and policies relating to energy efficiency which are contained in the state energy conservation plan issued in compliance with the Energy Policy and Conservation Act, 42 U.S.C. §§ 6321 et seq.

#### **10. Americans with Disabilities Act (ADA)**

**Authority:** 42 U.S.C. § 12101 et seq.; 29 U.S.C. § 794; 49 U.S.C. § 5301(d)

The Contractor agrees to comply with all applicable requirements of the Americans with Disabilities Act of 1990, as amended, 42 U.S.C. § 12101 et seq.; Section 504 of the Rehabilitation Act of 1973, as amended, 29 U.S.C. § 794; 49 U.S.C. § 5301(d); and applicable implementing regulations including 49 C.F.R. Part 37 (Transportation Services for Individuals with Disabilities). No person shall, solely by reason of disability, be excluded from participation in, be denied the benefits of, or be subjected to discrimination under any program or activity funded by or resulting from this Agreement.

#### **11. Additional Civil Rights Requirements**

**Authority:** 29 U.S.C. § 623; 42 U.S.C. §§ 2000d et seq., 6102, 12112, 12132; 49 U.S.C. § 5332; 29 C.F.R. Part 1630

**a. Nondiscrimination in Federal Public Transportation Programs:** The Contractor agrees to comply with 49 U.S.C. § 5332, which prohibits discrimination on the basis of race, color, creed, national origin, sex, or age and prohibits discrimination in employment or business opportunity.

**b. Title VI of the Civil Rights Act:** The Contractor agrees to comply with all provisions prohibiting discrimination on the basis of race, color, or national origin of Title VI of the Civil Rights Act of 1964, as amended, 42 U.S.C. §§ 2000d et seq., and with U.S. DOT regulations, “Nondiscrimination in Federally-Assisted Programs of the Department of Transportation,” 49 C.F.R. Part 21.

**c. Equal Employment Opportunity in Federal Transit:** The Contractor agrees to comply with all EEO provisions of 49 U.S.C. § 5332 and Title VII of the Civil Rights Act, as amended, 42 U.S.C. § 2000e.

**d. Nondiscrimination on the Basis of Sex:** The Contractor agrees to comply with Title IX of the Education Amendments of 1972, 20 U.S.C. §§ 1681 et seq., as applicable.

**e. Nondiscrimination on the Basis of Age:** The Contractor agrees to comply with the Age Discrimination Act of 1975, as amended, 42 U.S.C. §§ 6101 et seq.

**f. Access for Individuals with Disabilities:** The Contractor agrees to comply with 49 U.S.C. § 5301(d), 29 U.S.C. § 794, 42 U.S.C. §§ 12101 et seq. (ADA), 42 U.S.C. §§ 4151 et seq. (Architectural Barriers Act), and implementing regulations including: 49 C.F.R. Part 37; 49 C.F.R. Part 27; 36 C.F.R. Part 1192 and 49 C.F.R. Part 38; 28 C.F.R. Part 35; 28 C.F.R. Part 36; 41 C.F.R. Subpart 101-19; 29 C.F.R. Part 1630; 47 C.F.R. Part 64 Subpart F; and 36 C.F.R. Part 1194.

**g. Access to Services for Persons with Limited English Proficiency:** The Contractor agrees to comply with Executive Order No. 13166, “Improving Access to Services for Persons with Limited English Proficiency,” and with applicable U.S. DOT guidance on LEP services.

**h. Environmental Justice:** The Contractor agrees to comply with Executive Order No. 12898, “Federal Actions to Address Environmental Justice in Minority Populations and Low-Income Populations.”

**i. Flow-Down:** Contractor shall include the requirements of this Section 11 in every subcontract.

## **12. Clean Air**

**Authority:** 42 U.S.C. §§ 7401 et seq.

The Contractor agrees to comply with all applicable standards, orders, or regulations issued pursuant to the Clean Air Act, as amended, 42 U.S.C. §§ 7401 et seq. The Contractor agrees to report each violation to the City of Fayetteville / FAST and understands and agrees that the City will, in turn, report each violation as required to notify FTA and the appropriate EPA Regional Office. The Contractor also agrees to include these requirements in each subcontract exceeding \$100,000 financed in whole or in part with Federal assistance.

## **13. Clean Water**

**Authority:** 33 U.S.C. §§ 1251 et seq.

The Contractor agrees to comply with all applicable standards, orders, or regulations issued pursuant to the Federal Water Pollution Control Act, as amended, 33 U.S.C. §§ 1251 et seq. The Contractor agrees to report each violation to the City of Fayetteville / FAST and understands and agrees that the City will, in turn, report each violation as required to notify FTA and the appropriate EPA Regional Office. The Contractor also agrees to include these requirements in each subcontract exceeding \$100,000 financed in whole or in part with Federal assistance.

## **14. Debarment and Suspension**

**Authority:** 2 C.F.R. Parts 180 and 3000

The Contractor certifies, by submitting this Bid, that to the best of its knowledge and belief: (a) it is not presently debarred, suspended, proposed for debarment, declared ineligible, or voluntarily excluded from covered transactions by any Federal department or agency; (b) it has not within a three-year period preceding this Bid been convicted of or had a civil judgment rendered against it for commission of fraud or a criminal offense in connection with obtaining, attempting to obtain, or performing a public transaction; (c) it is not presently indicted for or otherwise criminally or civilly charged by a governmental entity with commission of fraud or other criminal offenses; and (d) it has not within a three-year period preceding this Bid had one or more public transactions terminated for cause or default. This certification applies to principals and to subcontractors.

## **15. Drug-Free Workplace**

**Authority:** 2 C.F.R. Part 182; 41 U.S.C. §§ 8101 et seq.

The Contractor agrees to comply with Federal Drug-Free Workplace requirements as outlined in 2 C.F.R. Part 182 and the Drug-Free Workplace Act of 1988, 41 U.S.C. §§ 8101 et seq. Contractor shall make good faith efforts to maintain a drug-free workplace, publish a workplace statement, and establish drug-free awareness programs for employees. Contractor shall take action concerning employees convicted of violating drug statutes in the workplace. Failure to comply with these provisions shall be considered a material breach of contract.

## **16. Buy America Requirements**

**Authority:** 49 U.S.C. § 5323(j); 49 C.F.R. Part 661

This contract is funded with FTA financial assistance. Contractor shall comply with 49 U.S.C. § 5323(j) and 49 C.F.R. Part 661, which provide that federal funds may not be obligated unless all steel, iron, and manufactured products used in FTA-funded projects are produced in the United States, unless a waiver has been granted by FTA or the product is subject to a general waiver.

**Contractor Requirements:**

- Must submit the appropriate Buy America Certification Form (Attachment O-1) with its Bid. A Bid submitted without a completed Buy America Certification may be deemed non-responsive;
- Must maintain documentation demonstrating compliance throughout project performance; and
- Must include Buy America requirements in all subcontracts.

**Definitions:** "Steel or iron products" means products from steel or iron produced in the United States, processed through all manufacturing stages including rolling, drawing, extruding, forging, casting, or fabricating. "Manufactured products" means a product composed of a combination of materials to serve a particular purpose, with more than 55% of the cost of all components manufactured in the United States.

**De Minimis Exception:** Buy America does not apply if the cost of non-compliant components or materials is less than \$2,500 (49 C.F.R. § 661.7(c)). If Contractor believes a de minimis exception applies, it shall certify that fact on the Buy America Certification Form.

**Waivers:** Contractor may request a waiver from the City if: (a) applying Buy America requirements would be inconsistent with public interest; (b) the iron, steel, or manufactured products are not produced in the United States in sufficient quantities or quality; or (c) inclusion of domestic materials would increase project cost by more than 25%. Waiver requests must be submitted to the City of Fayetteville / FAST for referral to FTA before contract execution.

**17. Contractor Assurance and Compliance with Federally Required Clauses**

By submitting a Bid, Contractor agrees to adhere to all applicable Federal provisions listed in this Attachment O. Failure to comply with applicable Federal provisions shall be considered a material breach of contract. Contractor is responsible for ensuring its compliance with all applicable Federal requirements and for ensuring that subcontractors, at all tiers of the Project as required, perform in accordance with the terms, conditions, and specifications of the contract, including all applicable Federal requirements.

**18. Resolution of Disputes, Breaches, or Other Litigation**

**Disputes:** Disputes arising in the performance of this contract that are not resolved by agreement of the parties shall be decided in writing by the authorized representative of the City of Fayetteville’s Director of Legal, Risk, and Procurement Services. This decision shall be final and conclusive unless within ten (10) days from the date of receipt, the Contractor furnishes a written appeal. The Contractor shall be afforded an opportunity to be heard and to offer evidence in support of its position. The decision of the City’s Director of Legal, Risk, and Procurement Services shall be binding upon the Contractor, subject to Contractor’s right to pursue judicial remedies.

**Performance During Dispute:** Unless otherwise directed by the City of Fayetteville, Contractor shall continue performance under this contract while matters in dispute are being resolved.

**Remedies:** Unless this contract provides otherwise, all claims, counterclaims, disputes, and other matters in question between the City of Fayetteville and the Contractor arising out of or relating to this agreement or its breach will be decided by mediation if the parties mutually agree, or in a court of competent jurisdiction within the State of North Carolina, Cumberland County (Fourteenth Judicial District) or, for federal matters, the United States District Court for the Eastern District of North Carolina.

**ATTACHMENT O-1**  
**BUY AMERICA CERTIFICATION FORM**  
**REQUIRED FOR FTA-FUNDED CONTRACTS**

49 U.S.C. § 5323(j) — 49 C.F.R. Part 661

**INSTRUCTIONS:** Check the applicable box below and sign. Submission of this form with your Bid is required. A Bid submitted without this completed certification may be deemed non-responsive. Only one box may be checked.

<b>Option 1</b>	<b>CERTIFICATE OF COMPLIANCE WITH 49 U.S.C. § 5323(j)(1) — FULL COMPLIANCE</b>
<input type="checkbox"/>	<p>The bidder hereby certifies that it will comply with the requirements of 49 U.S.C. § 5323(j)(1) and the applicable regulations in 49 C.F.R. Part 661. All steel, iron, and manufactured products used in this project will be produced in the United States, as defined in 49 C.F.R. Part 661.</p> <p>Date: _____ Signature: _____  Company Name: _____ Title: _____</p>
<b>Option 2</b>	<b>CERTIFICATE OF NON-COMPLIANCE WITH 49 U.S.C. § 5323(j)(1) — WAIVER REQUESTED</b>
<input type="checkbox"/>	<p>The bidder hereby certifies that it cannot comply with the requirements of 49 U.S.C. § 5323(j)(1), but it may qualify for an exception to the requirement pursuant to 49 U.S.C. § 5323(j)(2)(A), (B), or (C), and 49 C.F.R. §§ 661.7 or 661.11. Bidder must submit with this form a detailed explanation identifying the specific item(s) that cannot comply, the basis for the requested exception, and documentation supporting the exception claim. The City of Fayetteville / FAST will submit any waiver request to FTA for determination. Award may not be made until FTA has granted the waiver.</p> <p><b>Description of non-compliant item(s) and basis for waiver:</b></p> <p>_____</p> <p>_____</p> <p>Date: _____ Signature: _____  Company Name: _____ Title: _____</p>

<b>Option 3</b>	<b>DE MINIMIS EXCEPTION — 49 C.F.R. § 661.7(c)</b>
<input type="checkbox"/>	<p>The bidder certifies that the cost of non-compliant iron, steel, and manufactured products used in this project is less than \$2,500 and therefore qualifies for the de minimis exception under 49 C.F.R. § 661.7(c). Bidder certifies that it will comply with Buy America requirements for all items whose cost individually or in aggregate exceeds \$2,500.</p> <p>Estimated cost of non-compliant items: \$ _____</p> <p>Date: _____ Signature: _____</p> <p>Company Name: _____ Title: _____</p>

**EXHIBIT A**  
**DRAWINGS**

**Sealing Requirement:** Pursuant to N.C. Gen. Stat. § 89C-23, all construction drawings for this project must be prepared and sealed by a licensed North Carolina Professional Engineer. Drawings must be sealed before this ITB is issued. Include the PE's license number and seal date on each drawing sheet.

**Drawing Set Must Include at Minimum:**

- Cover Sheet — project location, general notes, applicable standards
- Site Plan — showing all four bus stop locations (Locations A, B, C, D) with dimensions
- Plan and Profile Sheets for each location
- ADA ramp details and truncated dome placement
- Concrete bus stop pad details (6'x20' and 8'x20' as applicable)
- Concrete sidewalk details
- Curb and gutter details
- Storm drainage details for Location D (junction box, 15" RCP)
- Traffic control plan
- City of Fayetteville Standard Details as applicable

**PROJECT SCOPE**

**THIS PROJECT CONSISTS OF:**  
**INSTALLATION OF 5' x 20' BUS STOP, ±1163 SF WIDE BUS PULL-OUT AREA, REMOVAL AND INSTALLATION OF PAVEMENT MARKINGS, AND ±92 SY OF CONCRETE SIDEWALK.**

# 1550 SKIBO ROAD PROPOSED BUS STOP & SIDEWALK

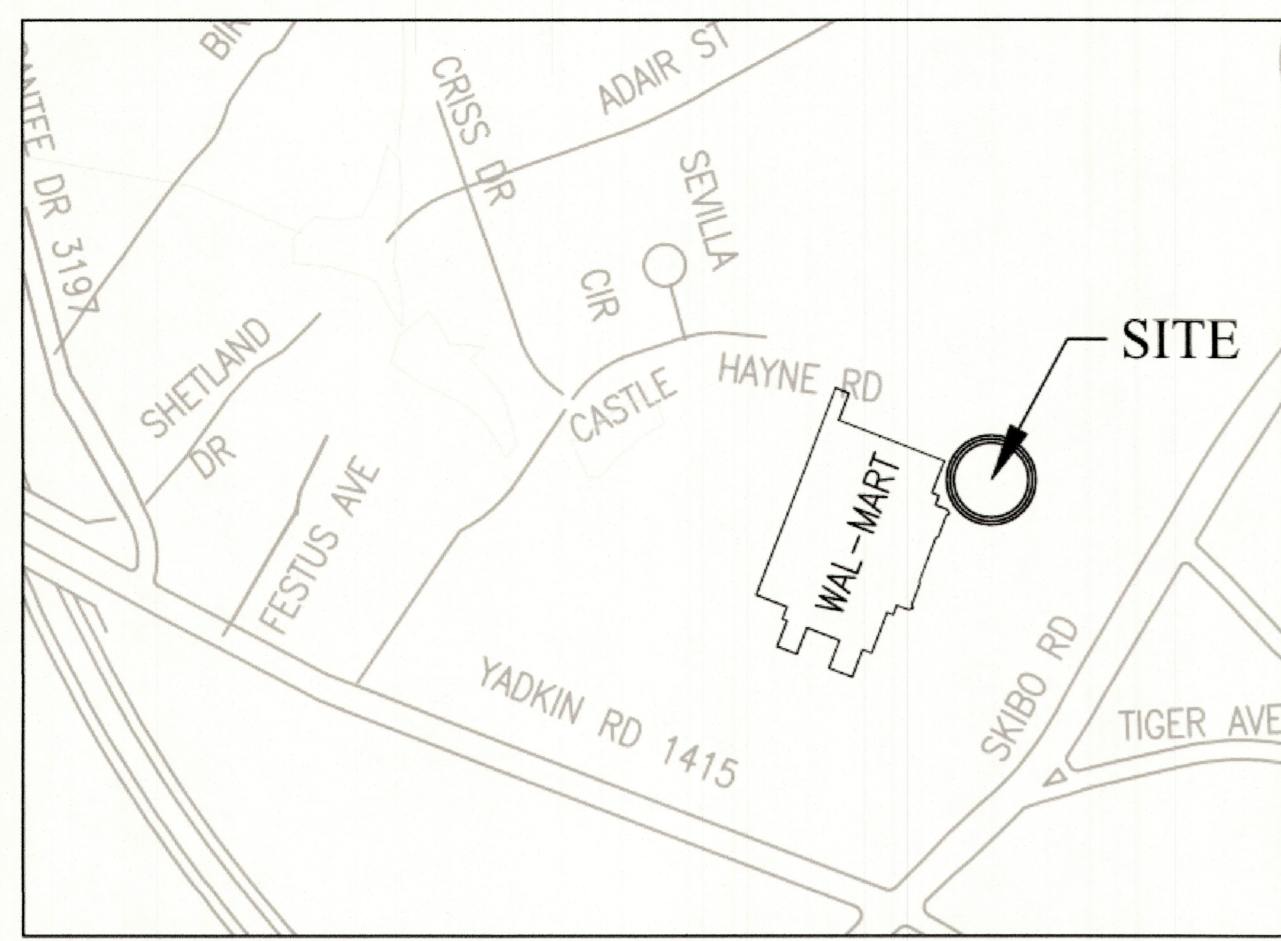

**VICINITY MAP**  
 SCALE: 1" = 500'

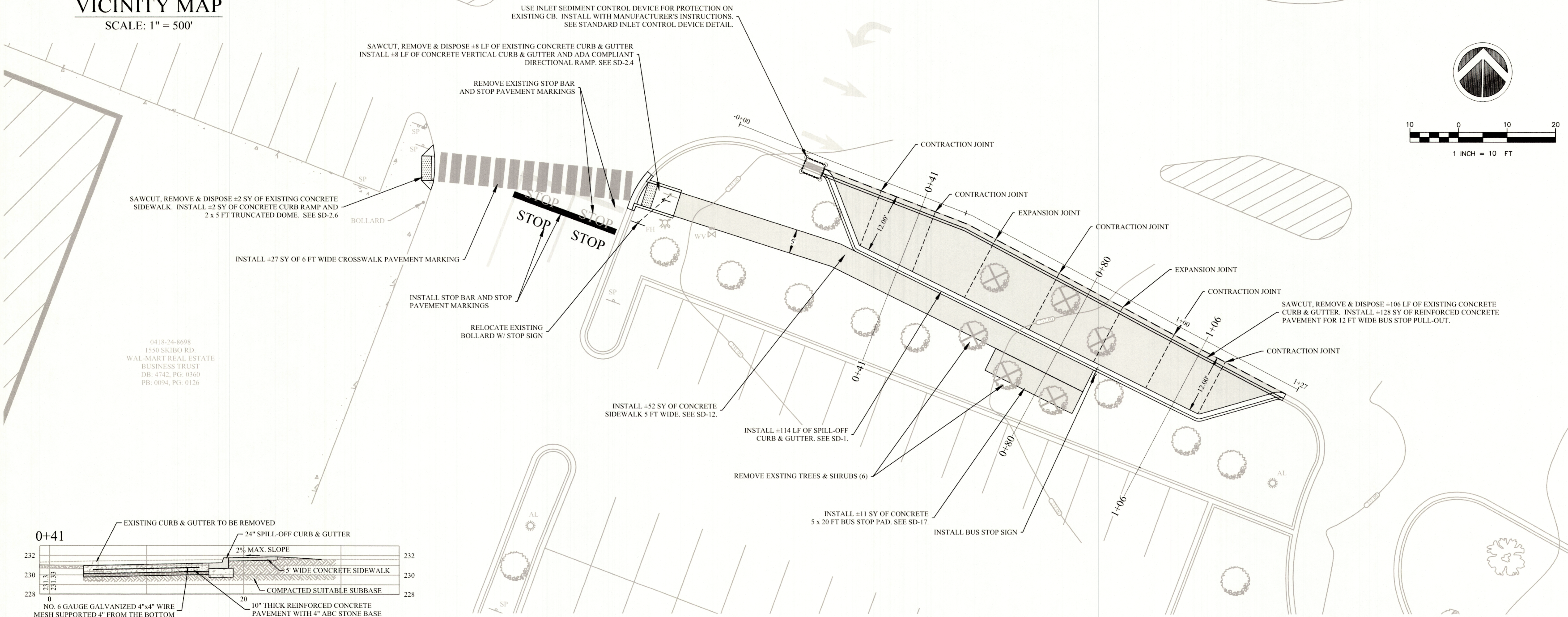

0418-24-8698  
 1550 SKIBO RD.  
 WAL-MART REAL ESTATE  
 BUSINESS TRUST  
 DB: 4742, PG: 0360  
 PB: 0094, PG: 0126

USE INLET SEDIMENT CONTROL DEVICE FOR PROTECTION ON EXISTING CB. INSTALL WITH MANUFACTURER'S INSTRUCTIONS. SEE STANDARD INLET CONTROL DEVICE DETAIL.

SAWCUT, REMOVE & DISPOSE ±8 LF OF EXISTING CONCRETE CURB & GUTTER. INSTALL ±8 LF OF CONCRETE VERTICAL CURB & GUTTER AND ADA COMPLIANT DIRECTIONAL RAMP. SEE SD-2.4

REMOVE EXISTING STOP BAR AND STOP PAVEMENT MARKINGS

SAWCUT, REMOVE & DISPOSE ±2 SY OF EXISTING CONCRETE SIDEWALK. INSTALL ±2 SY OF CONCRETE CURB RAMP AND 2 x 5 FT TRUNCATED DOME. SEE SD-2.6

INSTALL ±27 SY OF 6 FT WIDE CROSSWALK PAVEMENT MARKING

INSTALL STOP BAR AND STOP PAVEMENT MARKINGS

RELOCATE EXISTING BOLLARD W/ STOP SIGN

INSTALL ±52 SY OF CONCRETE SIDEWALK 5 FT WIDE. SEE SD-12.

INSTALL ±14 LF OF SPILL-OFF CURB & GUTTER. SEE SD-1.

REMOVE EXISTING TREES & SHRUBS (6)

INSTALL ±11 SY OF CONCRETE 5 x 20 FT BUS STOP PAD. SEE SD-17.

INSTALL BUS STOP SIGN

SAWCUT, REMOVE & DISPOSE ±106 LF OF EXISTING CONCRETE CURB & GUTTER. INSTALL ±128 SY OF REINFORCED CONCRETE PAVEMENT FOR 12 FT WIDE BUS STOP PULL-OUT.

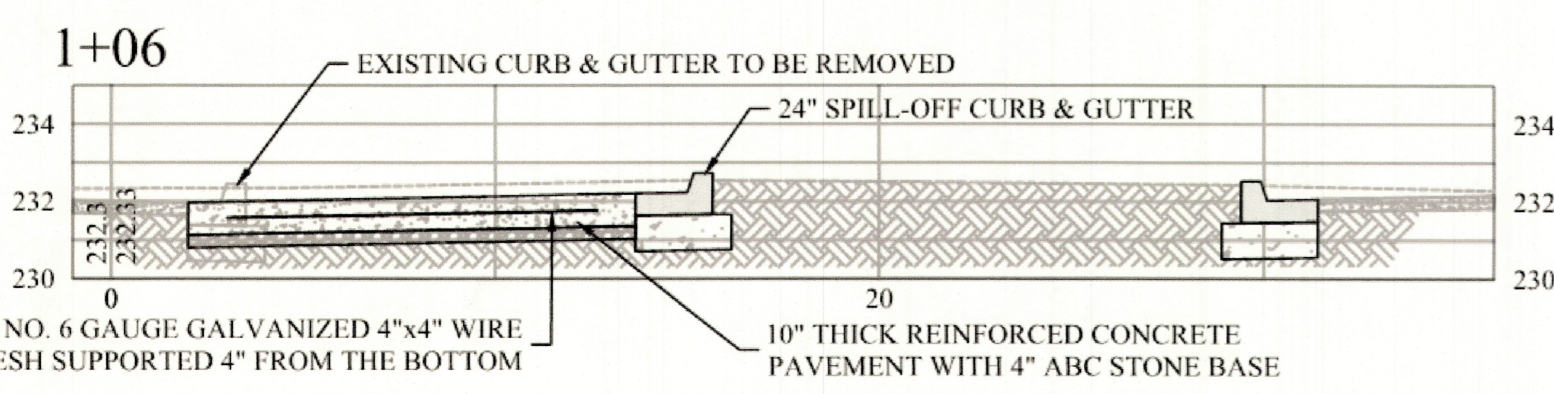
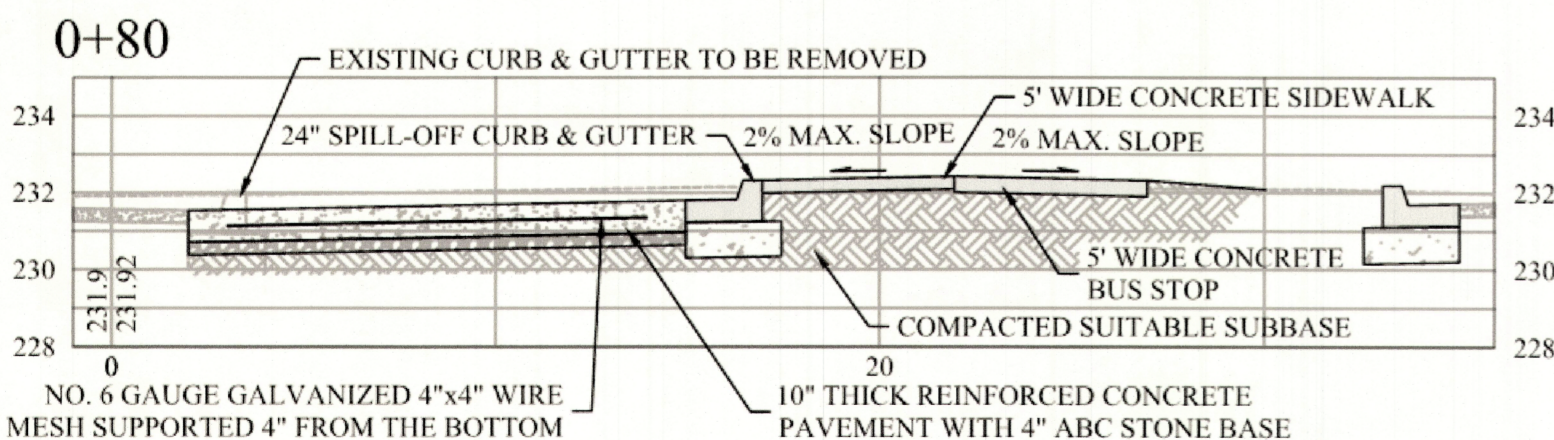
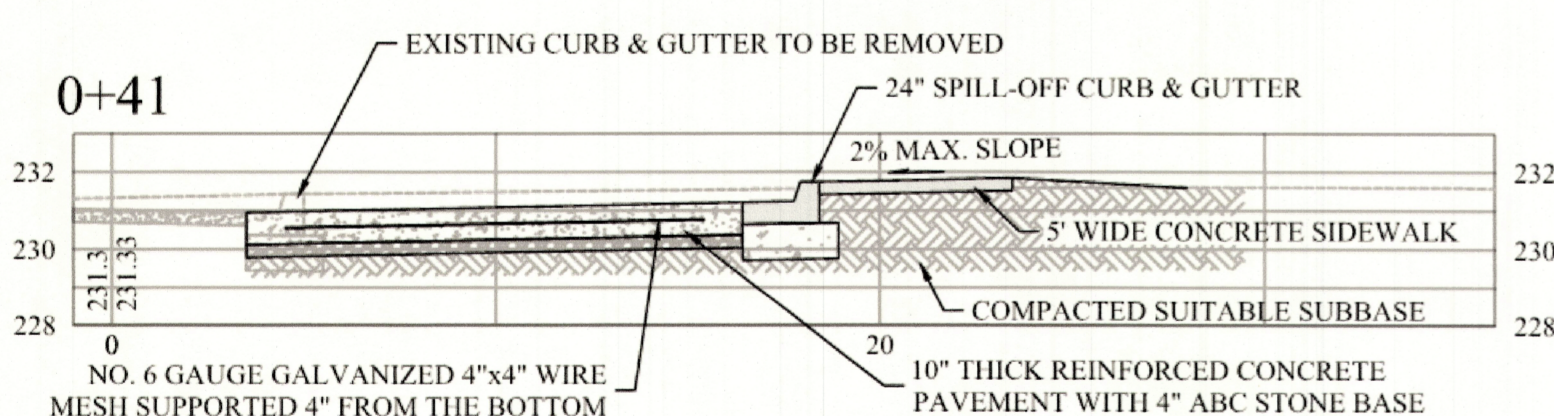

INDEX	
SHEET	SHEET DESCRIPTION
1	COVER SHEET & PLAN
2	LEGEND
3	GENERAL NOTES
4	DETAILS



Know what's below.  
 Call before you dig.

PROJECT CONTACTS CITY OF FAYETTEVILLE	
Engineering	Byron Reeves, PE, CFM Deputy Public Services Director - Engineering 433 Hay Street, Fayetteville, NC 28301 (910) 433-1301 byronreeves@fayettevillenc.gov
Construction Management	Jeff Riddle, PLS Construction Manager 339 Alexander Street, Fayetteville, NC 28301 (910) 433-1661 jeffreyriddle@fayettevillenc.gov
Traffic Services	Brian McGill, PE, PTOE Assistant Public Services Director for Traffic Services 339 Alexander Street, Fayetteville, NC 28301 (910) 433-1170 brianmcgill@fayettevillenc.gov

1550 SKIBO ROAD  
 BUS STOP & SIDEWALK  
 PLAN TYPE  
 COVER & PLAN  
 SHEET NUMBER  
 1 of 4

**FAYETTEVILLE**  
 AMERICA'S CAN DO CITY  
**ENGINEERING DIVISION**  
 PUBLIC SERVICES DEPARTMENT, NC 28301  
 433 HAY STREET, FAYETTEVILLE, NC 28301

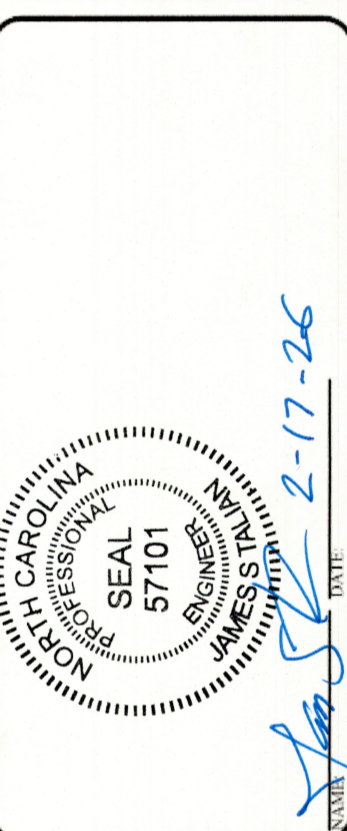

REV	REVISIONS	REV BY

DRAWN : V. ARAVEZ	DESIGN : V. ARAVEZ	SCALE : 1"=10'	DATE : 2/17/2026
CHECK : R. HENDRIX	APPROVED : J. TALLIAN		

# ABBREVIATIONS

ASPH - ASPHALT  
 B/C - BACK OF CURB  
 BM - BENCHMARK  
 BFP - BACK FLOW PREVENTER  
 CB - CATCH BASIN  
 CP - CABLEVISION PEDESTAL  
 C&G - CURB AND GUTTER  
 C/L - CHAIN LINK  
 CMP - CORRUGATED METAL PIPE  
 CO - CLEANOUT  
 CONC - CONCRETE  
 CONST - CONSTRUCTION  
 CP - CONTROL POINT  
 CTR - CENTER  
 DB - DEED BOOK  
 DEPT - DEPARTMENT  
 DI - DROP INLET  
 DIP - DUCTILE IRON PIPE  
 DWA - DRIVEWAY ASPHALT  
 DWB - DRIVEWAY BRICK  
 DWC - DRIVEWAY CONCRETE  
 DWD - DRIVEWAY DIRT  
 DWG - DRIVEWAY GRAVEL  
 E - EAST/EASTING  
 EOP - EDGE OF PAVEMENT  
 ESMT - EASEMENT  
 EV - ELECTRICAL VAULT  
 F/C - FACE OF CURB  
 FES - FLARED END SECTION  
 FH - FIRE HYDRANT  
 FOB - FIBER OPTIC BURIED  
 FOM - FIBER OPTIC MARKER  
 FP - FLAG POLE  
 GV - GAS VALVE  
 GW - GUY WIRE  
 GWV - GATE WATER VALVE  
 HDPE - HIGH DENSITY POLYETHYLENE  
 INV - INVERT  
 JB - JUNCTION BOX  
 LF - LINEAR FOOT  
 LOD - LIMITS OF DISTURBANCE  
 LP - LIGHT POLE  
 MAX - MAXIMUM  
 MB - MAILBOX  
 MHEL - MANHOLE ELECTRIC  
 MHSD - MANHOLE STORM DRAIN  
 MHSS - MANHOLE SANITARY SEWER  
 MHTP - MANHOLE TELEPHONE  
 N - NORTH/NORTHING  
 O.C. - ON CENTER  
 O/H - OVERHEAD  
 PVMT - PAVEMENT  
 PC - POINT OF CURVATURE  
 PERM - PERMANENT  
 PG - PAGE  
 PI - POINT OF INTERSECTION  
 PVC - POLYVINYL CHLORIDE  
 PP - POWER POLE  
 RCP - REINFORCED CONCRETE PIPE  
 R/W - RIGHT OF WAY  
 S - SOUTH  
 SC - SAWCUT  
 SD - STORM DRAIN  
 SF - SQUARE FOOT  
 SP - BOLLARD WITH SIGN POST  
 SS - SANITARY SEWER  
 STA - STATION  
 STD - STANDARD  
 SWA - SIDEWALK ASPHALT  
 SWB - SIDEWALK BRICK  
 SWC - SIDEWALK CONCRETE  
 SY - SQUARE YARD  
 TC - TRASH CAN  
 TD - TRUNCATED DOME  
 TCE - TEMPORARY CONSTRUCTION EASEMENT  
 TCP - TERRA COTTA PIPE  
 TP - TELEPHONE PEDESTAL  
 TSB - TRAFFIC SIGNAL BOX  
 TVP - TRAVERSE POINT  
 TYP - TYPICAL  
 U.O.N. - UNLESS OTHERWISE NOTED  
 UP - UTILITY POLE  
 W - WEST  
 WCR - WHEELCHAIR RAMP  
 WM - WATER METER  
 WV - WATER VAULT

	PROPOSED CONCRETE
	PROPOSED CONCRETE CURB AND GUTTER
	PROPOSED RIGHT-OF-WAY
	PROPOSED FENCE
	PROPOSED UNDERGROUND GAS
	PROPOSED UNDERGROUND WATER
	PROPOSED SANITARY SEWER
	PROPOSED STORM DRAIN
	PROPOSED TEMPORARY CONSTRUCTION EASEMENT
	PROPOSED EASEMENT
	SILT FENCE - LIMITS OF DISTURBANCE
	PROPOSED SWALE
	PROPOSED TRUNCATED DOMES
	PROPOSED SANITARY SEWER MAN HOLE
	PROPOSED STORM SEWER MAN HOLE
	PROPOSED ELECTRICAL MAN HOLE
	PROPOSED TELEPHONE MAN HOLE
	PROPOSED CATCH BASIN
	PROPOSED DROP INLET
	PROPOSED ELECTRICAL VAULT
	PROPOSED WATER VAULT
	PROPOSED WATER METER
	PROPOSED SANITARY SEWER CLEAN OUT
	PROPOSED POWER POLE
	PROPOSED LIGHT POLE
	PROPOSED FIRE HYDRANT
	PROPOSED GATE WATER VALVE
	PROPOSED GAS VALVE
	PROPOSED TREE
	PROPOSED SHRUB
	INLET PROTECTION
	PROPOSED FLAIED END SECTION
	PROPOSED HEADWALL

# LEGEND

	WETLANDS		EXISTING CONCRETE MONUMENT
	EXISTING CONCRETE/SIDEWALK		EXISTING SURVEY CONTROL MARKER
	EXISTING CONCRETE CURB AND GUTTER		EXISTING PROPERTY CORNER (EIR/ERB/SIR/EIP)
	EXISTING RIGHT-OF-WAY		EXISTING MAILBOX
	EXISTING FENCE		EXISTING TREE
	EXISTING UNDERGROUND GAS		EXISTING SHRUB
	EXISTING UNDERGROUND WATER		EXISTING FLAIED END SECTION
	EXISTING SANITARY SEWER		EXISTING HEADWALL
	EXISTING STORM SEWER		
	EXISTING FIBER OPTIC BURIED		
	EXISTING UNDERGROUND ELECTRIC		
	EXISTING OVERHEAD ELECTRIC		
	EXISTING TELEPHONE CABLE		
	EXISTING CABLEVISION		
	EXISTING TRAIN TRACKS		
	EXISTING EASEMENT		
	EXISTING SWALE		
	EXISTING SANITARY SEWER MAN HOLE		
	EXISTING STORM SEWER MAN HOLE		
	EXISTING ELECTRICAL MAN HOLE		
	EXISTING TELEPHONE MAN HOLE		
	EXISTING CATCH BASIN		
	EXISTING DROP INLET		
	EXISTING ELECTRICAL VAULT		
	EXISTING WATER VAULT		
	EXISTING WATER METER		
	EXISTING SANITARY SEWER CLEAN OUT		
	EXISTING POWER POLE		
	EXISTING LIGHT POLE		
	EXISTING FIRE HYDRANT		
	EXISTING WATER VALVE		
	EXISTING GAS VALVE		

1550 SKIBO ROAD  
 BUS STOP & SIDEWALK  
 SHEET NUMBER 2 of 4

**FAYETTEVILLE**  
 AMERICA'S CAN DO CITY  
 ENGINEERING DIVISION  
 433 HAY STREET, FAYETTEVILLE, NC 28501

NORTH CAROLINA  
 PROFESSIONAL SEAL  
 57101  
 DATE: 2-17-26

REVISIONS	REV. BY

DRAWN : V. ARAVEZ	DESIGN : V. ARAVEZ
CHECK : R. HENDRIX	SCALE : N/A
APPROVED : J. TALLIAN	DATE : 2/09/2026

**GENERAL NOTES:**

ACCESS TO SITES SHALL BE BY PUBLIC RIGHT-OF-WAYS AND UTILITY EASEMENTS. OTHER ACCESS LOCATIONS REQUIRED SHALL BE SECURED BY THE CONTRACTOR AT NO ADDITIONAL EXPENSE TO THE OWNER. SUPPLEMENTAL EROSION CONTROL MEASURES SHALL BE REQUIRED TO INCLUDE CONSTRUCTION ENTRANCES, SILT FENCING, RESTORATION, ETC.

THE CONTRACTOR SHALL BE REQUIRED TO PROVIDE THE CONSTRUCTION STAGING AREA AT HIS EXPENSE. A TEMPORARY USE PERMIT IS REQUIRED FOR THE STAGING AREA (ZONING 433-1705).

THE CONTRACTOR IS EXPECTED AND REQUIRED TO COOPERATE WITH THE PROPERTY OWNERS AFFECTED BY THE WORK. PRIVATE AGREEMENTS WITH PROPERTY OWNERS MUST BE IN WRITING ON A FORM APPROVED BY THE ENGINEER AND A COPY SHALL BE PROVIDED TO THE ENGINEER PRIOR TO PROCEEDING WITH CONSTRUCTION ACTIVITIES AFFECTED BY SAID AGREEMENT. THE AGREEMENT MUST SPECIFY THAT THE CITY AND THE ENGINEER SHALL BE HELD HARMLESS AGAINST ALL CLAIMS ARISING FROM THE AGREEMENT. THE OWNER DISCOURAGES PRIVATE AGREEMENTS. BEFORE FINAL ACCEPTANCE, A RELEASE FROM EACH PROPERTY OWNER THAT THE CONTRACTOR MADE AN AGREEMENT WITH SHALL BE REQUIRED. THE PROPERTY OWNER'S RELEASE IS A CONDITION OF FINAL ACCEPTANCE.

CONTRACTOR SHALL MAINTAIN A NEAT AND CLEAN JOB-SITE TO INCLUDE STAGING/STORAGE AREAS AS FOLLOWS:

- PERFORM DUST CONTROL BY WATERING DAILY OR AS DIRECTED BY THE ENGINEER.
- SWEEP STREETS A MINIMUM OF ONCE WEEKLY (FRIDAY) OR AS DIRECTED BY THE ENGINEER.
- BLADE, LEVEL AND RE-COMPACT ALL EXPOSED TRENCHES WEEKLY (OR AS DIRECTED BY THE ENGINEER) TO PRODUCE A SMOOTH "RIDE".
- PERFORM DAILY CLEAN-UP OF ALL DIRT, DEBRIS AND SCRAP MATERIALS.
- REMOVE EXCESS EQUIPMENT, MATERIALS, TOOLS, ETC. NOT NEEDED.

CONTRACTOR SHALL PROVIDE MEASURES DURING CONSTRUCTION TO SECURE THE SITE AND EXCAVATION FROM THE GENERAL PUBLIC AND COMPLY WITH ALL OSHA REGULATIONS. JOB SITE SAFETY IS THE EXCLUSIVE AND SOLE RESPONSIBILITY OF THE CONTRACTOR. OPEN EXCAVATION LEFT UNATTENDED OR OVER NIGHT IS NOT ACCEPTABLE AND SHALL BE FILLED IMMEDIATELY.

CONTRACTOR SHALL REPAIR OR REPLACE DRIVES DISTURBED BY CONSTRUCTION TO EXISTING OR BETTER CONDITIONS. NO SEPARATE PAYMENT UNLESS OTHERWISE INDICATED.

CONTRACTOR SHALL PROVIDE TEMPORARY FENCING WHERE FENCES ARE REMOVED FOR CONSTRUCTION. CONTRACTOR SHALL COORDINATE REMOVAL OF EXISTING FENCE AND INSTALLATION OF TEMPORARY FENCE WITH PROPERTY OWNER PRIOR TO CONSTRUCTION. REMOVAL OF TEMPORARY FENCE AND INSTALLATION OF PERMANENT FENCE MUST ALSO BE COORDINATED WITH PROPERTY OWNER. ALL REMOVAL, TEMPORARY, AND REPLACEMENT FENCING SHALL BE CONSIDERED INCIDENTAL TO THE CITY INSTALLATION AND NO SEPARATE PAYMENT SHALL BE MADE. CONTRACTOR SHALL REINSTALL ALL SHEDS, FENCES, ETC. TO AS GOOD OR BETTER THAN EXISTING CONDITIONS UNLESS OTHERWISE INDICATED. (NO SEPARATE PAYMENT).

CONTRACTOR SHALL REPLACE ALL DISTURBED MAILBOXES, SIGNS, ETC. DISTURBED DURING CONSTRUCTION WITHIN 24 HOURS OF DISTURBANCE. PERMANENT ROAD SIGNAGE DISTURBED SHALL BE REPLACED IMMEDIATELY AND IF NECESSARY ROADWAY SIGNS SHALL BE TEMPORARILY INSTALLED IN A LOCATION CONSISTENT WITH THE NCMUTCDD TO PROVIDE CONTINUOUS TRAFFIC AWARENESS OF ROADWAY CONDITIONS. (NO SEPARATE PAYMENT).

CONTRACTOR SHALL PROVIDE SECURITY FENCING, SECURITY GUARD, AND ANY AND ALL OTHER MEASURES CONTRACTOR DEEMS NECESSARY TO PROTECT EQUIPMENT AND MATERIALS STORED ON THE PROJECT. (NO SEPARATE PAYMENT).

WHERE CONTRACTOR CEASES WORK OPERATION FOR A 72 HOUR PERIOD OR LONGER, SUCH AS HOLIDAYS, ETC., THE FOLLOWING SHALL BE ACCOMPLISHED PRIOR TO THE WORK STOPPAGE.

- CONTRACTOR WILL STORE ALL EQUIPMENT IN THE CONTRACTOR STAGING AREA OR OFF SITE.
- THE CONTRACTOR SHALL SWEEP ALL STREETS, PERFORM GENERAL CLEANUP AND SHALL PERFORM MAINTENANCE ON ALL EXPOSED PATCHES.

CONTRACTOR SHALL SCHEDULE WORK AND MATERIAL DELIVERIES SO THAT STORED MATERIAL QUANTITIES ON THE JOB SITE SHALL BE MINIMIZED.

CONTRACTOR SHALL STORE ALL MATERIALS IN THE CONTRACTOR STAGING AREA 72 HOURS PRIOR TO INCORPORATING INTO THE WORK TO REDUCE OBSTRUCTIONS TO TRAFFIC AND INCONVENIENCE TO RESIDENTS.

**GENERAL NOTES FOR RESIDENT RELATIONS (MANDATORY):**

THE CONTRACTOR IS REQUIRED TO DEVELOP GOOD RELATIONS WITH THE RESIDENTS WHICH INCLUDE THE FOLLOWING MANDATORY MINIMUM REQUIREMENTS:

- NO SPEEDING WITH EQUIPMENT AND/OR VEHICLES (25 MPH MAX.)
- DO NOT BLOCK DRIVEWAYS AT ANY TIME
- DO NOT LITTER AT ANY TIME
- DO NOT USE RESIDENT'S WATER WITHOUT THEIR PERMISSION (SIGNED AGREEMENT REQUIRED)
- ALL PLUMBING CODE REQUIREMENTS FOR BACK FLOW PREVENTION WILL BE ADHERED TO
- RESPOND TO RESIDENT'S COMPLAINTS WITHIN 24 HOURS
- DO NOT USE ABUSIVE LANGUAGE, PROFANITY OR CAT-CALLING
- WEAR PROPER PROTECTIVE CLOTHING (HARD HATS, PROPER SHOES, SHIRTS, ETC.) AT ALL TIMES.
- MAINTAIN PROPER SAFETY MEASURES, PARTICULARLY ALONG OPEN TRENCHES, PLACING CONES ON RAISED MANHOLES AND BACK FILLING OPEN

TRENCHES IF CONSTRUCTION IS STOPPED AND THE OPEN TRENCH IS NOT MANNED.

- PERSONNEL MUST WEAR CITY APPROVED SAFETY VEST AT ALL TIMES WHILE WORKING IN THE CITY AND/OR NCDOT RIGHT-OF-WAY
- ALL TRAFFIC CONTROL FLAG PERSONS AND AT LEAST ONE PERSON ON EACH WORK CREW MUST BE FLUENT IN THE ENGLISH LANGUAGE

IF THE CONTRACTOR AND/OR SUBCONTRACTORS CANNOT ADQUATELY PERFORM AND/OR COMPLY WITH THESE REQUIREMENTS, THE INDIVIDUAL, SUBCONTRACTOR, OR EMPLOYEES MAY BE DIRECTED TO LEAVE THE PROJECT PERMANENTLY. INCONSIDERATE, NON-COOPERATIVE ATTITUDES AND ACTIONS WILL NOT BE TOLERATED.

**UTILITIES:**

UTILITIES ARE ILLUSTRATED FOR INFORMATION PURPOSES ONLY. THE CITY OR ENGINEER WILL NOT BE HELD RESPONSIBLE FOR THE ACCURACY OF UTILITY LOCATIONS, SIZES, DEPTHS, OR FOR COMPLETENESS OF UTILITY INFORMATION SHOWN.

PRIOR TO CONSTRUCTION, THE CONTRACTOR SHALL NOTIFY AND MEET WITH ALL UTILITY OWNERS. THE CONTRACTOR SHALL PROTECT ALL UTILITIES FROM DAMAGE CAUSED BY HIS OPERATIONS OR THOSE OF HIS AGENTS. THE CONTRACTOR SHALL HOLD THE CITY HARMLESS FOR ANY THIRD-PARTY INCONVENIENCE CREATED BY WORK OF HIS OWN FORCES OR THAT OF HIS AGENTS. ANY DAMAGES INCURRED SHALL BE THE CONTRACTORS FINANCIAL RESPONSIBILITY.

ADJUSTMENTS/RELOCATIONS WILL BE PERFORMED BY THE VARIOUS UTILITY OWNERS. THE CONTRACTOR SHALL COORDINATE WORK WITH UTILITY OWNERS SO AS NOT TO ADVERSELY AFFECT THE PROJECT SCHEDULE. THE CITY WILL NOT BE HELD RESPONSIBLE FOR ANY DELAYS OR DISRUPTIONS TO THE WORK SCHEDULE OF OTHER UTILITY OWNERS.

- FOR UTILITY LOCATES CALL NORTH CAROLINA ONE-CALL @ 811.
- FOR LOCATES OF UTILITIES NOT MEMBERS OF NORTH CAROLINA ONE-CALL CONTACT PROJECT MANAGER OR UTILITY COORDINATOR.

THE CONTRACTOR SHALL ADJUST ALL WATER VALVES, WATER METER BOXES AND WATER VAULTS TO FINISHED GRADE. WATER METERS, MANHOLES, AND CLEANOUTS LOCATED IN SIDEWALKS OR CONCRETE DRIVEWAYS SHALL BE INSTALLED IN ACCORDANCE WITH PWC REQUIREMENTS. NO ABOVE GROUND UTILITY BOXES, POWER POLE, OR OTHER STRUCTURES ARE TO BE LOCATED WITHIN THE SIDEWALK AREA. THE SIDEWALK AREA IS TO BE FREE OF OBSTACLES.

PRIOR TO COMMENCEMENT OF ANY WORK WITHIN EASEMENTS OR RIGHT-OF-WAYS, THE CONTRACTOR IS REQUIRED TO NOTIFY CONCERNED UTILITY COMPANIES IN ACCORDANCE TO GS 87-102. CONTRACTOR SHALL VERIFY LOCATION OF EXISTING UTILITIES PRIOR TO BEGINNING CONSTRUCTION. NO SEPARATE PAYMENT. EXISTING UTILITIES SHOWN ARE TAKEN FROM MAPS FURNISHED BY VARIOUS UTILITY COMPANIES AND HAVE NOT BEEN PHYSICALLY LOCATED (i.e. GAS, FIBER OPTIC, ETC.).

THE CONTRACTOR SHALL DIG UP EACH UTILITY WHICH MAY CONFLICT WITH CONSTRUCTION 14 DAYS IN ADVANCE TO VERIFY LOCATIONS (HORIZONTALLY AND VERTICALLY) TO ALLOW THE ENGINEER AN OPPORTUNITY TO ADJUST THE DESIGN TO AVOID CONFLICTS (NO SEPARATE PAYMENT).

STORM DRAINAGE REPAIRS BY CONTRACTOR DUE TO CONSTRUCTION DAMAGE AND JOINTS EXPOSED DURING CONSTRUCTION SHALL BE INSPECTED BY THE OWNER PRIOR TO BACKFILLING.

**MAIL BOXES:**

THE CONTRACTOR SHALL RELOCATE ALL MAIL BOXES AS REQUIRED BY SECTION 107-12 OF THE NCDOT STANDARD SPECIFICATIONS FOR ROADS AND STRUCTURES. COORDINATE THIS WORK WITH THE U.S. POSTAL SERVICE.

**TREES, SHRUBS, AND HEDGES:**

ALL TREES THAT ARE TO REMAIN ARE TO BE PROTECTED WITH TREE PROTECTION BARRIERS ACCEPTABLE TO THE CITY ARBORIST OR LANDSCAPE ARCHITECT. CONTRACTOR SHALL OBTAIN APPROVAL FROM THE CITY ARBORIST OR LANDSCAPE ARCHITECT PRIOR TO ROOT PRUNING. WHEN ROOT PRUNING IS ABSOLUTELY NECESSARY, CUT ROOTS CLEANLY USING A DISC TRENCHER OR OTHER APPROVED METHOD.

CONTRACTOR SHALL OBTAIN APPROVAL FROM THE CITY PRIOR TO REMOVING ANY TREES. ALL TREES LOCATED WITHIN THE LOT THAT ARE TO REMAIN AFTER CONSTRUCTION SHALL BE INSPECTED BY THE CITY TO VERIFY THEY ARE SUITABLE TO REMAIN.

**GRADING:**

THE CONTRACTOR SHALL BE RESPONSIBLE FOR ALL BORROW MATERIAL REQUIRED TO CONSTRUCT PROJECT AS SHOWN ON THE CONTRACT DOCUMENTS.

ALL EXCAVATED MATERIALS THAT ARE NOT REQUIRED OR ARE UNSUITABLE FOR THE PROJECT SHALL BE CONSIDERED WASTE AND SHALL BE HAULED OFF SITE AND DISPOSED IN A SAFE AND LEGAL MANNER AT THE CONTRACTOR'S EXPENSE.

**EROSION CONTROL:**

CONTRACTOR SHALL NOT DISTURB ANY AREAS OUTSIDE OF THE DESIGNATED EASEMENT AREAS.

THE CONTRACTOR SHALL MAINTAIN EROSION CONTROL DEVICES IN ACCORDANCE WITH THE APPROPRIATE CITY AND STATE EROSION AND SEDIMENT CONTROL ORDINANCES. THE CONTRACTOR SHALL PREVENT STANDING WATER DUE TO CONSTRUCTION.

**SAWCUTS:**

THE CONTRACTOR SHALL SAWCUT EXISTING ASPHALT AND/OR CONCRETE SURFACES PRIOR TO REMOVAL UNLESS OTHERWISE DIRECTED BY THE ENGINEER. SAW CUT WIDTH SHALL BE 1 FOOT MINIMUM FOR THE EXISTING EDGE OF PAVEMENT. SAWCUT PAVEMENT SHALL BE REPLACED AS WELL AS ADDITIONAL PAVEMENT REQUIRED TO TIE-IN TO FACE OF PROPOSED CURB OR GUTTER.

**STORM DRAINAGE STRUCTURE, PIPE & GRADING NOTES:**

PIPE INVERT ELEVATIONS HAVE PRECEDENCE OVER SLOPES. HOWEVER, SLOPES SHALL NOT BE DECREASED FROM THOSE SHOWN ON PLAN WITHOUT PRIOR APPROVAL FROM THE ENGINEER.

ALL STORM DRAINAGE PIPE TO BE CLASS III REINFORCED CONCRETE UNLESS OTHERWISE NOTED. PIPE LENGTHS INDICATED ON PLAN ARE APPROXIMATE ONLY.

NO SOIL DISTURBANCE OR COMPACTION, CONSTRUCTION MATERIALS, TRAFFIC, TRENCHING, OR OTHER LAND DISTURBING ACTIVITY SHALL BE PERMITTED BEYOND LIMITS OF GRADING WITHOUT PRIOR APPROVAL FROM THE OWNER AND CITY ENGINEERING DEPT.

THE CONTRACTOR SHALL IMMEDIATELY REPORT TO THE CITY OF FAYETTEVILLE ANY DISCREPANCIES FOUND BETWEEN ACTUAL CONDITION AND CONSTRUCTION DOCUMENTS AND SHALL WAIT FOR INSTRUCTION FROM THE CITY INSPECTOR PRIOR TO PROCEEDING.

MANHOLE RIM ELEVATIONS SHOWN ON THE PLANS ARE APPROXIMATE. NEW MANHOLE RING AND COVERS SHALL BE INSTALLED FLUSH WITH THE SURROUNDING GRADE SO AS TO AVOID DAMAGE TO MOTOR VEHICLES DURING CONSTRUCTION. THEY ARE TO BE ADJUSTED TO MATCH THE SURROUNDING PROPOSED GRADE PRIOR TO PLACING THE NEW SURFACE COURSE.

THE CONTRACTOR SHALL DESIGN, FURNISH, AND INSTALL ANY TRENCH STABILIZATION NECESSARY TO MAINTAIN EXCAVATION FOR PIPE AND DRAINAGE STRUCTURE INSTALLATION. THE CONTRACTOR SHALL BE RESPONSIBLE FOR INSTALLATION AND REMOVAL OF ANY TRENCH STABILIZATION. THE CONTRACTOR SHALL ALSO BE RESPONSIBLE FOR ANY DAMAGE TO ADJACENT STRUCTURES RESULTING FROM THE INSTALLATION, REMOVAL OR ABSENCE OF TRENCH STABILIZATION.

GRADES, ELEVATIONS AND LOCATIONS SHOWN ARE APPROXIMATE, AS DIRECTED BY THE ENGINEER. THEY MAY BE ADJUSTED TO ACCOMMODATE UNFORESEEN CONDITIONS. ALL PROPOSED GRADES ARE FINISH GRADES.

THE CONTRACTOR SHALL BACKFILL OPEN EXCAVATIONS AT THE END OF EACH WORKING DAY. AT DRAINAGE STRUCTURE LOCATIONS, THE EXCAVATION SHALL BE COVERED WITH METAL PLATES WHEN PRACTICAL OR COMPLETEY ENCLOSED WITH SAFETY NETTING.

**STOCKPILING NOTE:**

ANY ONSITE STOCKPILING IS TO BE COORDINATED AND APPROVED BY A CITY INSPECTOR. THE STOCKPILE WILL BE PROVIDED WITH GROUND COVER WITHIN 15 WORKING DAYS OF PROJECT COMPLETION.

EXCESS SUITABLE SOIL EXCAVATED DURING CONSTRUCTION SHALL BE STOCKPILED FOR USE ON THE PROJECT OR DISPOSED OF OFF-SITE AS DIRECTED BY THE ENGINEER. THE CONTRACTOR SHALL NOT BE ALLOWED TO STOCKPILE MATERIALS OR EXCESS MATERIALS IN THE STREET RIGHT-OF-WAYS AT ANY TIME UNLESS APPROVED BY THE ENGINEER. THE CONTRACTOR SHALL PROVIDE A SUFFICIENT AND SUITABLE STOCKPILE AREA AND LOCATION AT THE CONTRACTOR'S EXPENSE.

**ORDER OF PRECEDENCE GENERAL NOTES/TECHNICAL SPECIFICATIONS/PHOTOS:**

THE NOTES CONTAINED HEREIN ARE INTENDED TO SUPPLEMENT THE TECHNICAL SPECIFICATIONS AND PROVIDE EASY REFERENCE FOR THE CONTRACTOR. IN NO CASE SHALL THESE NOTES VOID ANY PART, SECTION OR REQUIREMENT OUTLINED IN THE TECHNICAL SPECIFICATIONS CONTAINED IN THE CONTRACT DOCUMENTS. IF CONFLICTS OCCUR BETWEEN THE TECHNICAL SPECIFICATIONS AND THE NOTES CONTAINED HEREIN, THE TECHNICAL SPECIFICATIONS SHALL SUPERSEDE.

**NCDOT ENCROACHMENT SPECIAL PROVISIONS:**

CONTRACTOR TO NOTIFY COUNTY MAINTENANCE ENGINEER, (910) 364-0602, A MINIMUM OF THREE (3) DAYS BEFORE CONSTRUCTION IS TO BEGIN.

AN EXECUTED COPY OF THE ENCROACHMENT AGREEMENT SHALL BE PRESENT AT THE CONSTRUCTION SITE AT ALL TIMES DURING CONSTRUCTION. THE NORTH CAROLINA DEPARTMENT OF TRANSPORTATION RESERVES THE RIGHT TO STOP ALL WORK UNLESS EVIDENCE OF APPROVAL CAN BE SHOWN.

SEE THE ENCROACHMENT AGREEMENT FOR A FULL LIST OF SPECIAL PROVISIONS.

**TRAFFIC CONTROL**

CONTRACTOR SHALL PROVIDE TRAFFIC CONTROL PLANS FOR WORK ZONE TRAFFIC CONTROL TO CITY TRAFFIC SERVICES DEPARTMENT (910-433-1660) FOR CITY STREETS AND DIVISION 6, DISTRICT 2 (910-364-0601) FOR NCDOT STREETS. CONTRACTOR SHALL NOT PLACE ANY TRAFFIC CONTROL DEVICES WITHOUT HAVING APPROVAL FROM APPLICABLE TRANSPORTATION DEPARTMENT EITHER NCDOT OR THE CITY OF FAYETTEVILLE.

CONTRACTOR SHALL INSURE ACCESS TO ALL PROPERTIES BY PROPERTY OWNERS AT ALL TIMES.

CONTRACTOR SHALL NOTIFY CITY ENGINEERING OFFICE ONE WEEK IN ADVANCE OF ANY ROAD CLOSING AND COORDINATE ALL ROAD CLOSINGS/UTILITY INTERRUPTIONS WITH PROPERTY OWNERS AFFECTED 48 HOURS PRIOR TO CLOSING/INTERRUPTING SERVICES.

MINIMUM ONE WAY TRAFFIC SHALL BE MAINTAINED AT ALL TIMES UNLESS ROAD CLOSURE IS APPROVED BY CITY OF FAYETTEVILLE TRAFFIC SERVICES DEPARTMENT IN WRITING, 5 DAYS IN ADVANCE OF ROAD CLOSURE. AN APPROVED DETOUR PLAN PREPARED BY THE CONTRACTOR SHALL BE REQUIRED AND THE MEASURES INSTALLED PRIOR TO CLOSURE.

CONTRACTOR SHALL COORDINATE/NOTIFY TRAFFIC SERVICES DAILY (BEFORE 2:00 P.M.) AS TO WHICH STREETS WILL BE UNDER CONSTRUCTION IMPEDING TRAFFIC FLOW THE FOLLOWING DAY.

THE CONTRACTOR SHALL NOT IMPEDE TRAFFIC AT ANY TIME UNTIL THE APPROVED TRAFFIC CONTROL DEVICES ARE IN PLACE.

ALL TRAFFIC CONTROL MEASURES, DEVICES, INSTALLATION, METHODS, SEQUENCING AND PLANS SHALL BE IN STRICT ACCORDANCE WITH MUTCD, NCDOT, AND CITY OF FAYETTEVILLE TRAFFIC SERVICES.

1550 SKIBO ROAD  
BUS STOP & SIDEWALK

PLAN TYPE  
GEN. NOTES

SHEET NUMBER  
3 of 4

**FAYETTEVILLE**  
AMERICA'S C&O CITY

ENGINEERING DIVISION  
433 HAY STREET, FAYETTEVILLE, NC 28301

REV.	REVISIONS	REV. BY

DRAWN : V. ARAVEZ	DESIGN : V. ARAVEZ	SCALE : N/A	DATE : 2/09/2026
CHECK : R. HENDRIX			
APPROVED : J. ITALIAN			

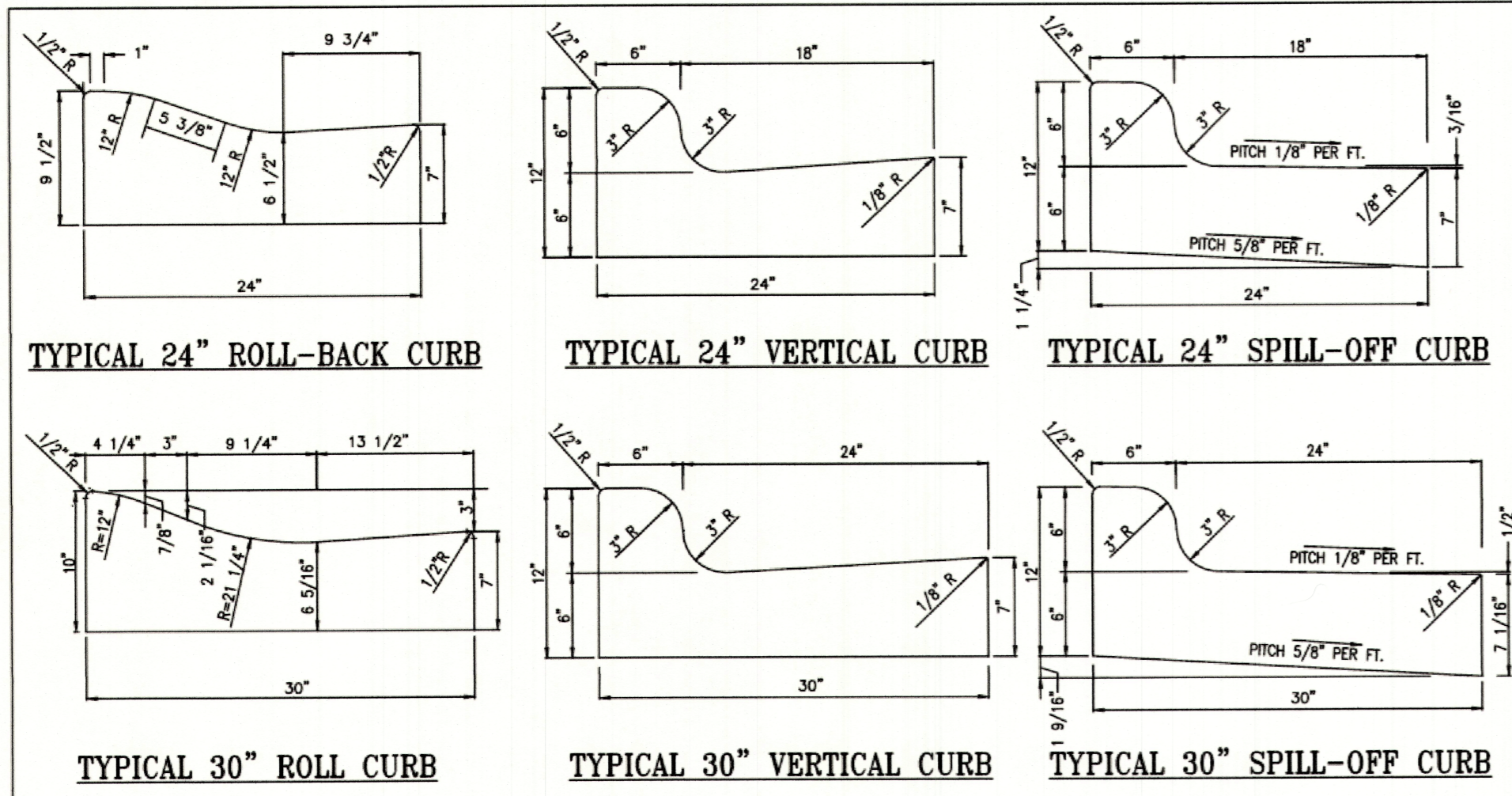

- NOTES:  
 1. ALL CURBS CONSTRUCTED OF 2500 PSI CONCRETE.  
 2. PLACE GROOVE JOINTS 1" DEEP AT 12'-6" INTERVALS BETWEEN EXPANSION JOINTS.  
 3. CURB SHALL BE DEPRESSED AT INTERSECTIONS TO PROVIDE FOR FUTURE ACCESSIBLE RAMPS.  
 4. TOP 6" OF SUBGRADE BENEATH THE CURB AND GUTTER SHALL BE COMPACTED TO 100% STANDARD PROCTOR DENSITY.  
 5. ADOPTED FROM NCDOT STANDARD NO. 846.01

**FAYETTEVILLE!** ENGINEERING DIVISION  
 433 HAY ST. 28301  
 (910) 433-1656  
<http://www.fayettevillenc.gov>

**24" AND 30" CURB DETAILS**

Not to Scale  
 Review Date: JULY 2024

**SD-1**

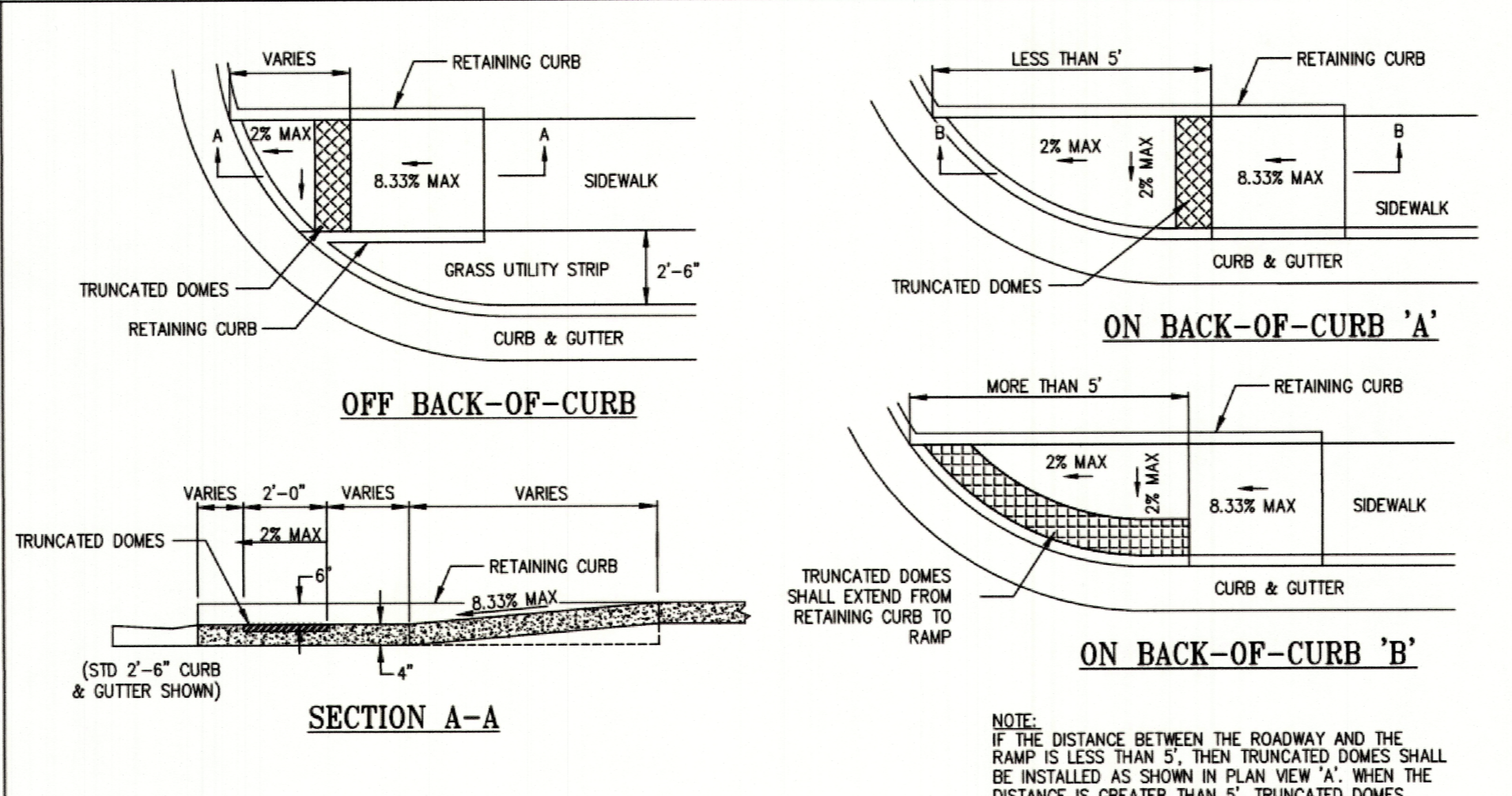

**FAYETTEVILLE!** ENGINEERING DIVISION  
 433 HAY ST. 28301  
 (910) 433-1656  
<http://www.fayettevillenc.gov>

**DIRECTIONAL CURB RAMP**

Not to Scale  
 Review Date: JULY 2024

**SD-2.4**

SEE SHEET SD-2.8 FOR WHEELCHAIR RAMP NOTES.

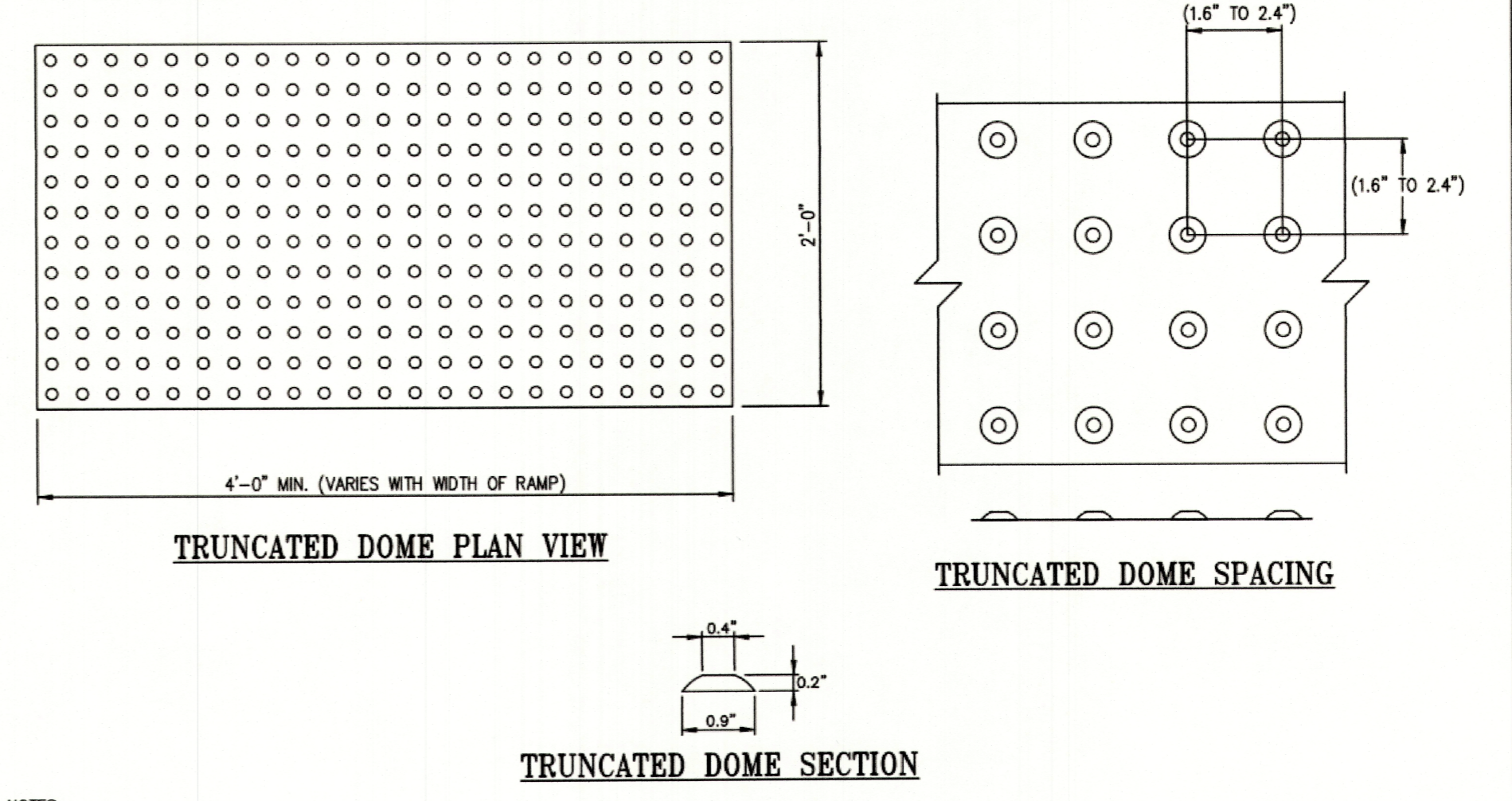

NOTES:  
 1. ALL DETECTABLE WARNING DEVICES USED IN NEW CONSTRUCTION SHALL BE OF A RIGID PRECAST OR EMBEDDED PRODUCT APPROVED BY THE CITY ENGINEER. RETRO FIT MATS WILL ONLY BE ALLOWED ON EXISTING RAMPS WITH PRIOR APPROVAL OF THE CITY ENGINEER FOR MATERIAL TYPE AND INSTALLATION (E. RESURFACING).  
 2. WIDTH OF DETECTABLE WARNING AREA SHALL BE A MINIMUM OF 4 FEET AND VARY WITH WIDTH OF RAMP.  
 3. LENGTH OF DETECTABLE WARNING AREA SHALL BE 2 FEET REGARDLESS OF SECTION WIDTH.  
 4. DETECTABLE WARNING AREA CAN BE SQUARE WHERE USED IN A CURB RADIUS.  
 5. DETECTABLE WARNING DOMES SHALL BE ALIGNED ON A SQUARE GRID IN THE PREDOMINANT DIRECTION OF TRAVEL TO PERMIT WHEELS TO ROLL BETWEEN DOMES.  
 6. IF PAVERS ARE TO BE USED, PAVERS SHALL BE 6" THICK AND CAST FROM 5000 PSI CONCRETE.  
 7. MATS ARE TO BE RIGID WITH TURN DOWN EDGES EMBEDDED IN CONCRETE TO ELIMINATE TRIP HAZARD.  
 8. TRUNCATED DOMES ARE TO BE BLACK IN COLOR.  
 9. ADOPTED FROM NCDOT STANDARD NO. 846.06.

**FAYETTEVILLE!** ENGINEERING DIVISION  
 433 HAY ST. 28301  
 (910) 433-1656  
<http://www.fayettevillenc.gov>

**TRUNCATED DOME DETAILS**

Not to Scale  
 Review Date: JULY 2024

**SD-2.6**

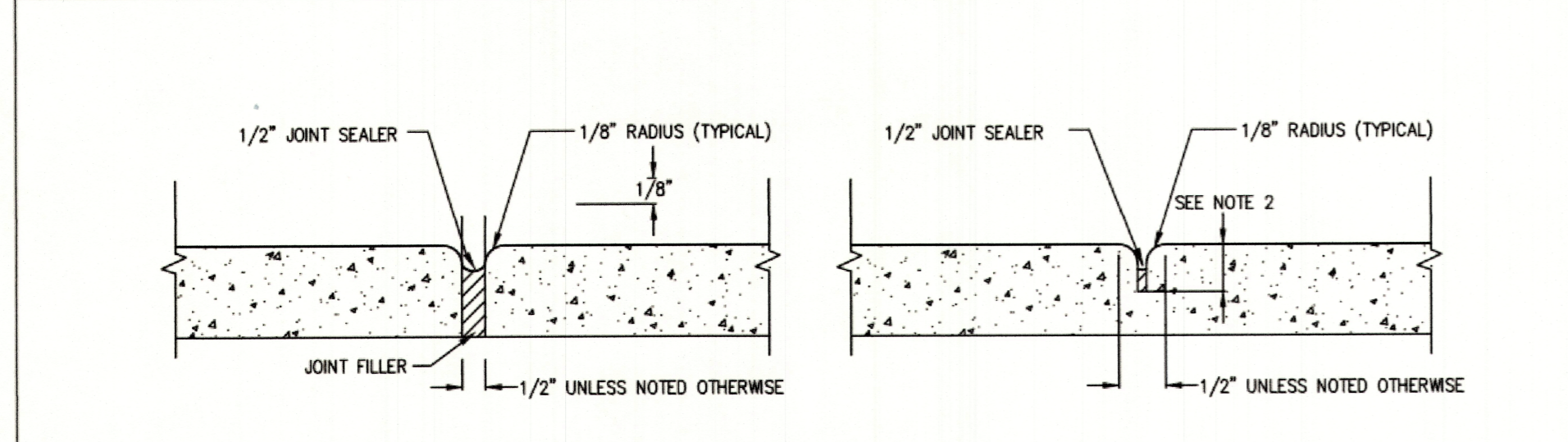

- NOTES:  
 1. PLACE CONTRACTION JOINTS AT 10' INTERVALS, EXCEPT THAT A 15' SPACING MAY BE USED WHEN A MACHINE IS USED OR WHEN SATISFACTORY SUPPORT FOR THE FACE FORM CAN BE OBTAINED WITHOUT THE USE OF TEMPLATES AT 10' INTERVALS.  
 2. JOINT SPACING MAY BE ALTERED IF REQUIRED BY THE ENGINEER.  
 3. CONTRACTION JOINTS MAY BE INSTALLED WITH THE USE OF TEMPLATES OF FORMED BY OTHER APPROVED METHODS.  
 4. FILL ALL CONSTRUCTION JOINTS, EXCEPT IN 8" x 6" MEDIAN CURB, WITH JOINT FILLER AND SEALER.  
 5. SPACE EXPANSION JOINTS AT 90' INTERVALS AND ADJACENT TO ALL RIGID OBJECTS.  
 6. REFER TO NCDOT DETAILS 846.01 AND 848.01 FOR MORE INFORMATION.

**FAYETTEVILLE!** ENGINEERING DIVISION  
 433 HAY ST. 28301  
 (910) 433-1656  
<http://www.fayettevillenc.gov>

**CONTRACTION AND EXPANSION JOINT**

Not to Scale  
 Review Date: JULY 2024

**SD-3**

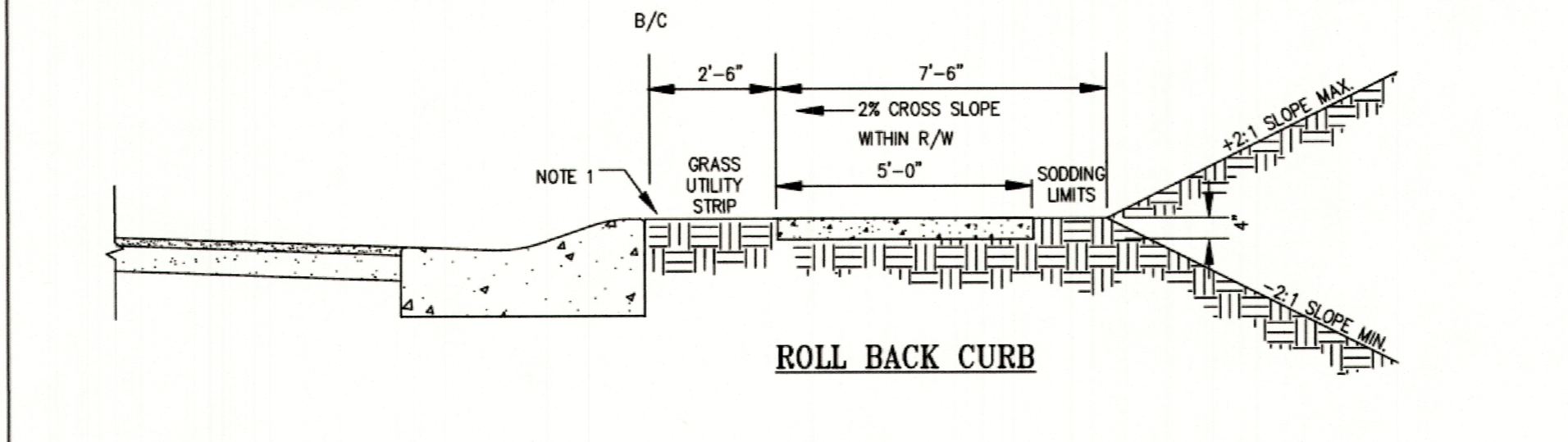

NOTES:  
 1. VERTICAL CURB - GRASS UTILITY STRIP MAY BE REMOVED UPON APPROVAL OF THE CITY ENGINEER. IF NO GRASS UTILITY STRIP, INSTALL 1/2" EXPANSION JOINT MATERIAL BETWEEN BACK OF CURB AND SIDEWALK.  
 2. PLACE CONTRACTION JOINTS AT 5' INTERVALS, EXCEPT THAT A 30' SPACING MAY BE USED WHEN A MACHINE IS USED OR WHEN SATISFACTORY SUPPORT FOR THE FACE FORM CAN BE OBTAINED WITHOUT THE USE OF TEMPLATES AT 10' INTERVALS.  
 3. SEE DETAIL SD-9 TYPICAL RESIDENTIAL DRIVEWAY APRON AND DETAIL SD-9-1 TYPICAL COMMERCIAL DRIVEWAY APRON.  
 4. SODDING LIMITS INCLUDE THE GRASS UTILITY STRIP BETWEEN THE BACK OF CURB AND THE SIDEWALK AS WELL AS 26" BEYOND THE SIDEWALK.

**FAYETTEVILLE!** ENGINEERING DIVISION  
 433 HAY ST. 28301  
 (910) 433-1656  
<http://www.fayettevillenc.gov>

**TYPICAL SIDEWALK SECTION & SODDING LIMITS**

Not to Scale  
 Review Date: JULY 2024

**SD-12**

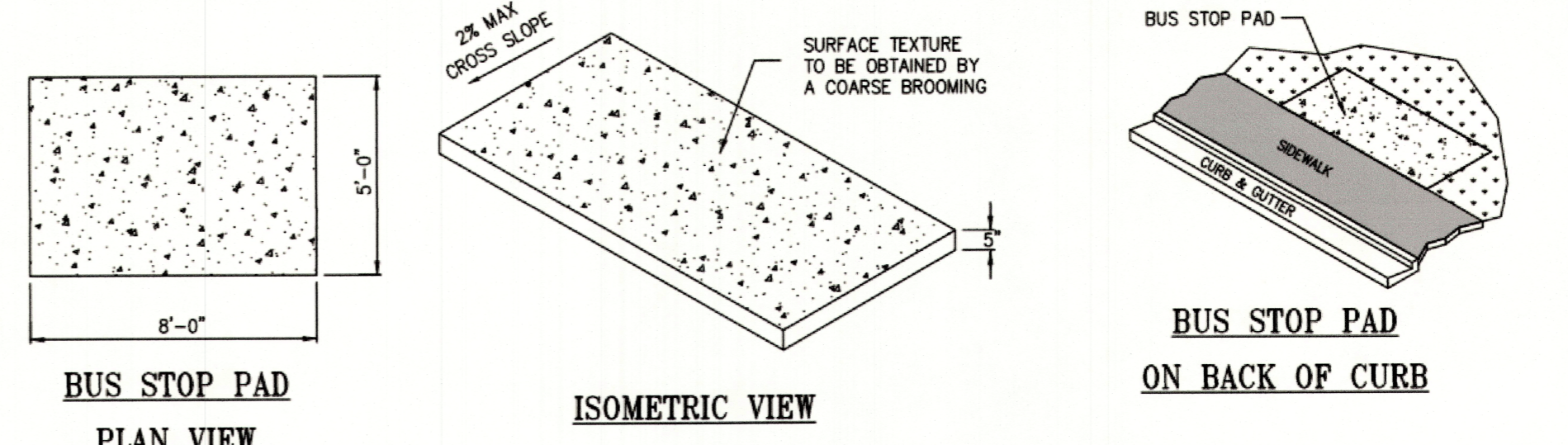

**FAYETTEVILLE!** ENGINEERING DIVISION  
 433 HAY ST. 28301  
 (910) 433-1656  
<http://www.fayettevillenc.gov>

**BUS STOP SHELTER PAD - PLAN VIEW**

Not to Scale  
 Review Date: JULY 2024

**SD-17**

DETAIL OF BUS STOP PAD

NOTES:  
 1. BUS STOP PAD SHALL BE PLACED BEHIND THE SIDEWALK.  
 2. IF SIDEWALK IS OFF THE BACK OF CURB, THE BUS STOP SHELTER PAD WIDTH SHALL BE 5'-0"  
 3. IF SIDEWALK IS ON THE BACK OF CURB, THE BUS STOP SHELTER PAD WIDTH SHALL BE 5'-0"  
 4. CONCRETE SHALL DEVELOP AT 28 DAYS A MIN COMPRESSIVE STRENGTH OF 2500 PSI.

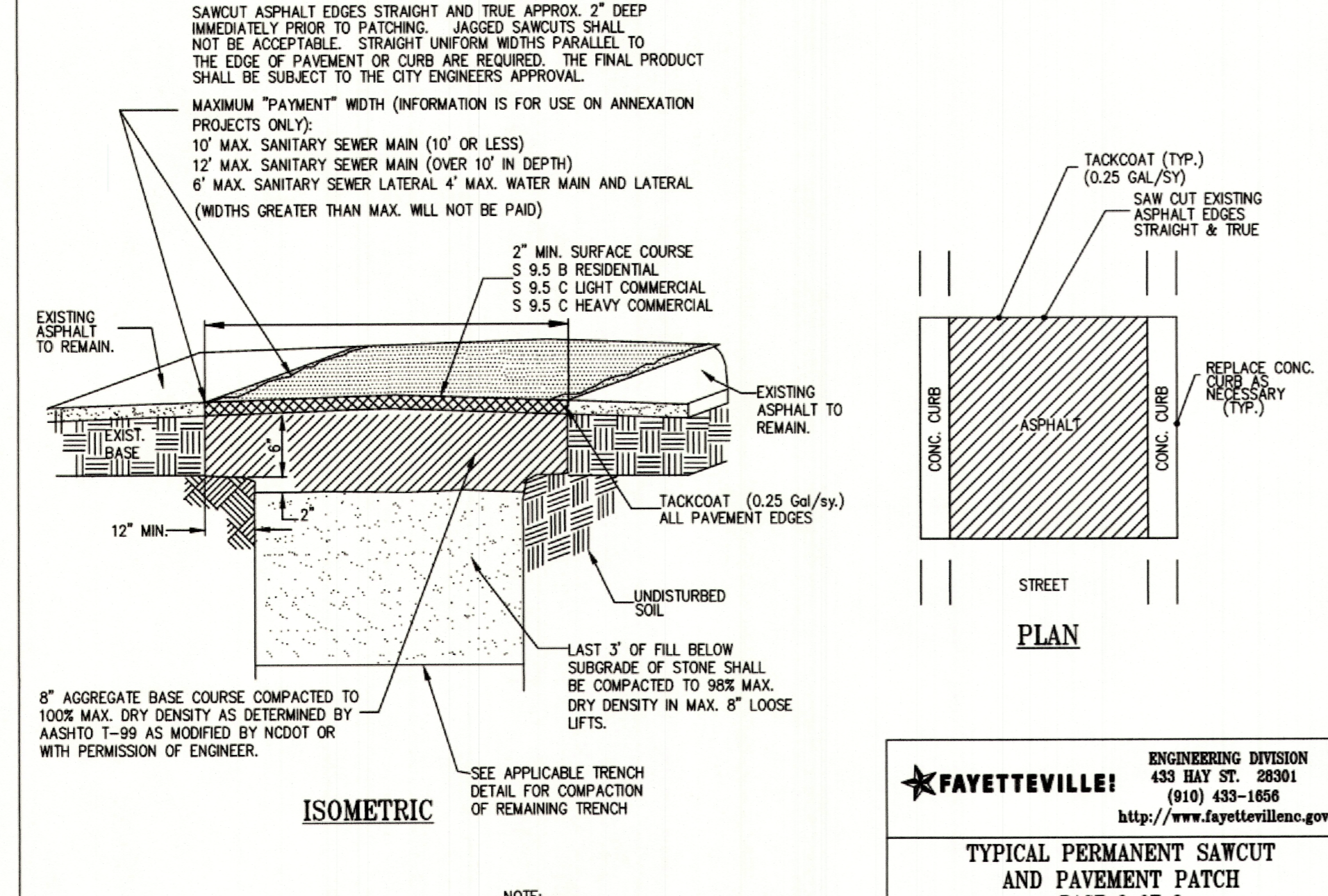

**FAYETTEVILLE!** ENGINEERING DIVISION  
 433 HAY ST. 28301  
 (910) 433-1656  
<http://www.fayettevillenc.gov>

**TYPICAL PERMANENT SAWCUT AND PAVEMENT PATCH PAGE 2 OF 3**

Not to Scale  
 Review Date: JULY 2024

**SD-11.1**

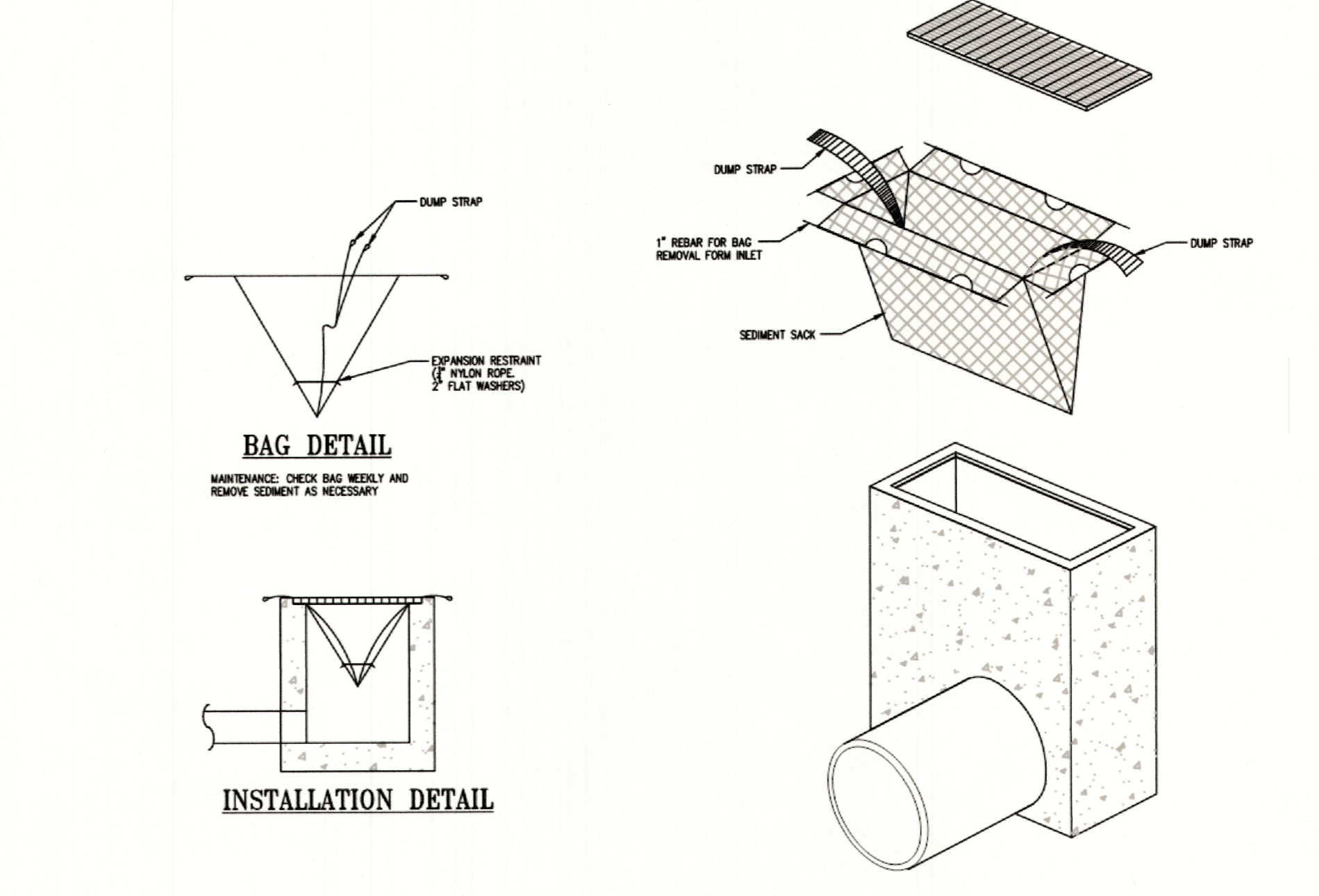
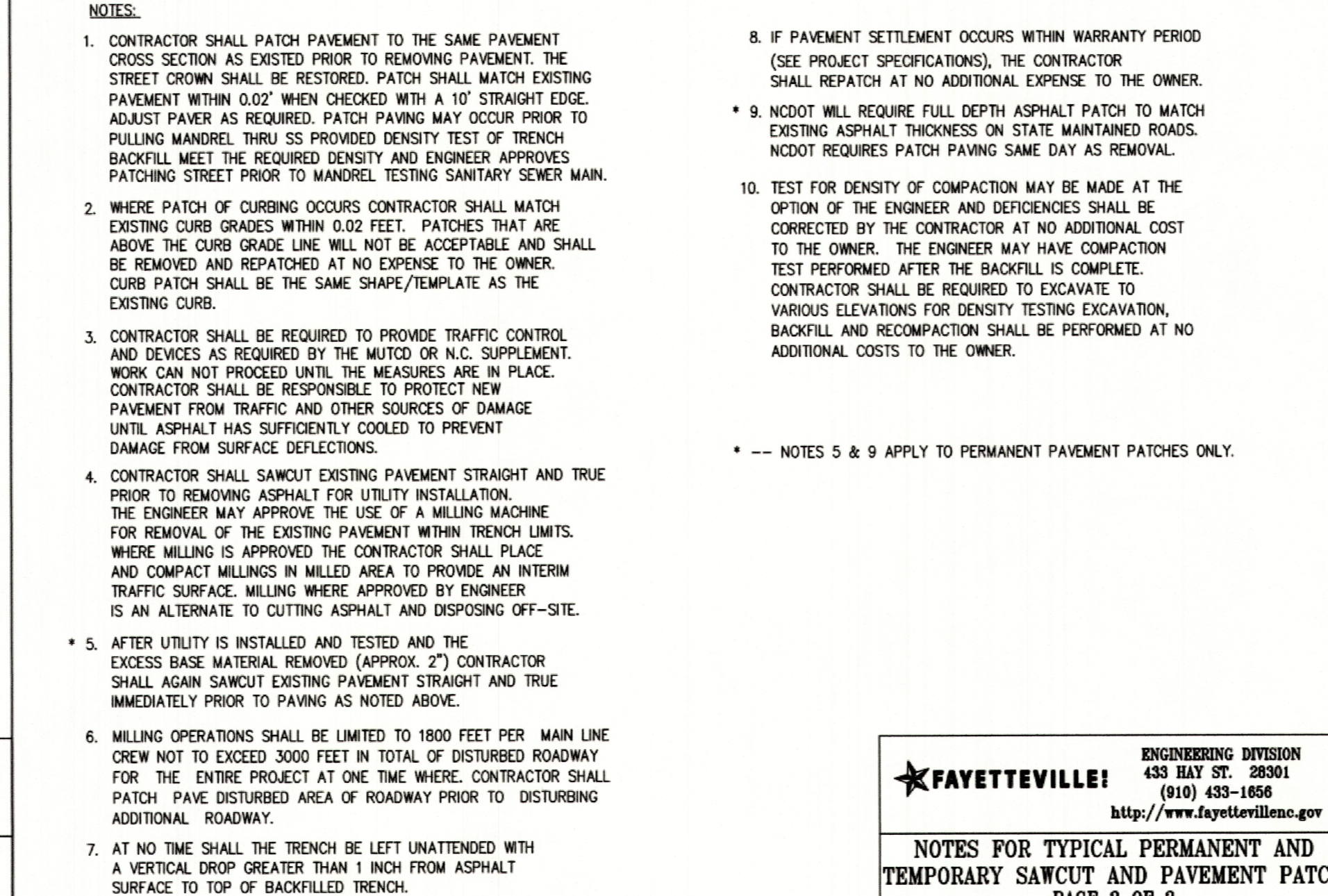

**FAYETTEVILLE!** ENGINEERING DIVISION  
 433 HAY ST. 28301  
 (910) 433-1656  
<http://www.fayettevillenc.gov>

**STANDARD INLET SEDIMENT CONTROL DEVICE**

Not to Scale  
 Review Date: JULY 2024

**SD-11.2**

DESIGN: V. ARAVEZ  
 CHECK: R. HENDRIX  
 APPROVED: J. T. ALIAN

REVISIONS:  
 REV. 1: V. ARAVEZ  
 REV. 2: R. HENDRIX

DATE: 2/09/2026

SCALE: N/A

DRAWN: V. ARAVEZ

DETAILED BY: J. T. ALIAN

DATE: 2/09/2026

SCALE: N/A

DESIGN: V. ARAVEZ

CHECK: R. HENDRIX

APPROVED: J. T. ALIAN

REVISIONS:  
 REV. 1: V. ARAVEZ  
 REV. 2: R. HENDRIX

DATE: 2/09/2026

SCALE: N/A

DRAWN: V. ARAVEZ

DETAILED BY: J. T. ALIAN

DATE: 2/09/2026

SCALE: N/A

DESIGN: V. ARAVEZ

CHECK: R. HENDRIX

APPROVED: J. T. ALIAN

1550 SKIBO ROAD  
 BUS STOP & SIDEWALK

FLAT TYPE  
 DETAILS

SHEET NUMBER  
 4 of 4

**FAYETTEVILLE!**  
 AMERICAS CAN DO CITY

ENGINEERING DIVISION  
 PUBLIC SERVICES DEPARTMENT  
 433 HAY STREET, FAYETTEVILLE, NC 28301

REVISIONS:  
 REV. 1: V. ARAVEZ  
 REV. 2: R. HENDRIX

DATE: 2/09/2026

SCALE: N/A

DRAWN: V. ARAVEZ

DETAILED BY: J. T. ALIAN

DATE: 2/09/2026

SCALE: N/A

DESIGN: V. ARAVEZ

CHECK: R. HENDRIX

APPROVED: J. T. ALIAN

## **EXHIBIT B**

**The Skibo Road Bus Stop & Sidewalk Construction Contract is incorporated herein by reference as Exhibit B of this ITB. A complete copy of the draft contract is provided with this solicitation package for review by all prospective bidders before submission of Bids.**

### **Key Contract Terms (Summary for Bidder Reference):**

- Contract Amount: Award amount based on competitive bid (total of Attachment B unit prices applied to quantities)
- Contract Duration: 75 calendar days from Notice to Proceed
- Liquidated Damages: Per the rate established in Article 6.3 of the Contract
- Retainage: 5% of each progress payment
- Payment Terms: Applications for Payment due by the 21st of each month; City pays within 45 days per N.C. Gen. Stat. § 143-134.1
- Sales Tax Certificates: Required with each Application for Payment beginning with the first application
- Bonds: Not required (contract value below applicable statutory thresholds)
- Davis-Bacon: Applies; weekly certified payrolls required
- Buy America: Applies per 49 U.S.C. § 5323(j)
- Change Orders: Engineer reviews and recommends; City executes; unit prices first preference
- Governing Law: North Carolina; Cumberland County venue

**NOTE TO BIDDERS:** Submission of a Bid constitutes acceptance of the terms and conditions in the Draft Contract Agreement. The city reserves the right to make revisions to the Draft Contract prior to award. Bidders are responsible for reviewing the final contract terms before award. Any objections or proposed modifications must be submitted in writing prior to contract execution.

# CONSTRUCTION CONTRACT

## 1550 Skibo Road Bus Stop & Sidewalk Construction Project

FAYETTEVILLE AREA SYSTEM OF TRANSIT (FAST)

CITY OF FAYETTEVILLE, NORTH CAROLINA

<b>Project Name/Description:</b>	1550 Skibo Road Bus Stop & Sidewalk Construction Project
<b>Site Address:</b>	1550 Skibo Road, Fayetteville, NC
<b>City Department:</b>	Fayetteville Area System of Transit (FAST)
<b>Vendor Name:</b>	
<b>Total Contract Amount:</b>	\$
<b>Funding Source:</b>	<input checked="" type="checkbox"/> Federally-Funded (FTA) <input type="checkbox"/> General Fund Balance
<b>Federal Funds Amount:</b>	\$
<b>General Fund Amount:</b>	\$
<b>Federal Agency (if applicable):</b>	Federal Transit Administration (FTA) — 49 U.S.C. Chapter 53
<b>Davis-Bacon Act Applies:</b>	<input checked="" type="checkbox"/> Yes <input type="checkbox"/> No
<b>Bid Proposal Date:</b>	
<b>Council Approval Date:</b>	
<b>Contract Start Date:</b>	
<b>Projected Completion Date (75 days):</b>	

**THIS CONTRACT**, made this \_\_\_\_\_ day of \_\_\_\_\_, 20\_\_\_\_, by \_\_\_\_\_, hereinafter called **Contractor**, and the **City of Fayetteville, North Carolina**, acting on behalf of the Fayetteville Area System of Transit (FAST), hereinafter called **City**. Collectively, Contractor and City shall be referred to as Parties.

## WITNESSETH

**WHEREAS**, a Contract for the 1550 Skibo Road Bus Stop & Sidewalk Construction Project has been awarded to Contractor by City for \$ \_\_\_\_\_, a sum equal to the aggregate cost of the work to be done and for labor, materials, equipment, apparatus, and supplies furnished at the prices and rates respectively named in the Proposal/Bid attached as Exhibit 1;

**AND WHEREAS**, this Contract is funded in whole or in part with federal financial assistance from the Federal Transit Administration (FTA), an agency of the U.S. Department of Transportation, through FTA programs under 49 U.S.C. Chapter 53, and federal requirements therefore apply throughout this Contract;

**AND WHEREAS**, it was provided in said Award that a formal contract would be executed by and between Contractor and City, evidencing the terms of said Award and completing all work as outlined under Special Provisions and Standard Specifications (Exhibit 3) within the schedule as shown in the Special Provisions;

**NOW, THEREFORE**, Contractor does hereby covenant and agree with City that it will faithfully perform and execute such work and furnish such labor, materials, equipment, apparatus and supplies, in accordance with each and every one of the conditions, covenants, stipulations, terms, and provisions contained in said Specifications and Provisions and in accordance with the Plans, at and for a sum equal to the aggregate cost of the work done at the prices and rates respectively named in the proposal attached, and will well and faithfully comply with and perform each and every obligation imposed upon it by said Plans and Specifications and the terms of said Award.

## **ARTICLE 1: PAYMENT OBLIGATIONS**

---

Contractor shall promptly make payments to all persons supplying materials in the execution of the work and to all laborers and others employed thereon.

**Sales Tax Certificates:** Contractor shall furnish with **each** Application for Payment, beginning with the first application, on City-provided forms, an affidavit certifying the total cost of materials and North Carolina Sales Tax paid on such materials included in the application. In the event an application does not include taxable items, the certificate is still required and must certify that fact. Applications for Payment submitted without the required certificate may be denied approval and payment until the certificate is provided.

## **ARTICLE 2: CONTRACTOR RESPONSIBILITIES AND LIABILITY**

---

### **2.1 Property Damage**

Contractor shall be responsible for all damages to property of the City of Fayetteville, North Carolina, that may be consequent upon the normal procedure of its work or that may be caused by or result from the negligence of Contractor, its employees or agents, during the progress of or connected with the execution of the work, whether within the limits of the work or elsewhere. Contractor must restore all property so injured to a condition as good as it was when Contractor entered upon the work.

### **2.2 General Liability**

Contractor shall furthermore be responsible for and required to make good at its expense any and all damages of whatever nature to persons or property arising during the period of the Contract, caused by carelessness, neglect, or want of due precaution on the part of Contractor, its agents, employees or workmen.

## 2.3 Indemnification

To the extent permitted by law, Contractor shall indemnify and save harmless the City of Fayetteville, North Carolina, FAST, and the officers and agents thereof from all claims, suits, and proceedings of every name and description which may be brought against the City, FAST, or the officers and agents thereof, for or on account of any injuries or damages to persons or property received or sustained by any person or persons, firm or corporation, or by or in consequence of any materials used in said work or by or on account of any improper material or workmanship in its construction, or by or on account of any accident, or of any other act or omission of Contractor, its agents, employees, servants or workmen.

Contractor assumes entire responsibility and liability for losses, expenses, demands and claims in connection with or arising out of any injury, or alleged injury (including death) to any person, or damage, or alleged damage, to property of the City or others sustained or alleged to have been sustained in connection with or to have arisen out of or resulting from the negligence of the Contractor, its subcontractors, agents, and employees, in the performance of the work, and agrees to indemnify and hold harmless the City, FAST, its officials, employees or volunteers from any and all such losses, expenses, damages, demands and claims and agrees to defend any suit or action brought against them, and to pay all damages, costs and expenses in connection therewith. Indemnification by the Contractor does not constitute a waiver of the City's governmental immunity in any respect under North Carolina law.

## 2.4 Subcontracts and Contingent Assignment

### 2.4.1 Subcontractual Relations and Flow-Down

(a) By appropriate written agreement, Contractor shall require each Subcontractor, to the extent of the Work to be performed by the Subcontractor, to be bound to Contractor by the terms of the Contract Documents and to assume toward Contractor all obligations and responsibilities, including responsibility for safety and federal compliance, that Contractor assumes toward City under the Contract Documents. Each subcontract agreement shall preserve and protect City's rights under the Contract Documents with respect to the Work to be performed by the Subcontractor. Contractor shall require each Subcontractor to enter into similar agreements with Sub-subcontractors.

(b) All subcontracts shall include substantially the following provisions:

- **Flow-Down of Terms.** To the extent of the work to be performed by Subcontractor: (A) Subcontractor is bound to Contractor by the terms of the Contract between City and Contractor, and (B) Subcontractor assumes toward Contractor all obligations and responsibilities that Contractor assumes toward City under the Contract. City's rights under the Contract with respect to the Work to be performed by Subcontractor are preserved and protected. City is an intended third-party beneficiary of this subcontract.
- **Obligation to Continue Performance.** If Contractor is terminated by City, and even if Contractor defaults in a manner that would give Subcontractor the right to terminate this subcontract, Subcontractor agrees that upon written request by City, a substitute contractor, or any surety obligated under bonds relating to the Contract, Subcontractor will continue to perform its obligations under this subcontract on the same terms and conditions for and on account of City, such substitute contractor, or the surety. If requested, Subcontractor will execute a separate document evidencing this commitment. Assignment is subject to the

prior rights of the surety. City shall be responsible to Subcontractor only for those obligations of Contractor that accrue after City exercises rights under this provision.

- **Federal Requirements Flow-Down.** All applicable federal requirements contained in Article 17 of this Contract shall be incorporated into each subcontract at every tier. Subcontractor certifies compliance with all applicable federal requirements, including but not limited to FTA requirements, Davis-Bacon, EEO, Buy America, Debarment, and Drug-Free Workplace.

#### 2.4.2 Contingent Assignment of Subcontracts

**(a) Assignment to City.** Each subcontract agreement for a portion of the Work is hereby assigned by Contractor to City, subject to the following conditions:

- **Effectiveness.** Assignment becomes effective only upon: (i) termination of this Contract by City for cause pursuant to Article 23.2; and (ii) City's written acceptance of the specific subcontract(s) by notice to Contractor and the affected Subcontractor(s).
- **Surety Priority.** Assignment is subject to the prior rights of any surety obligated under payment and performance bonds provided pursuant to N.C. Gen. Stat. § 44A-26.

**(b) City's Rights Upon Assignment.** Upon accepting assignment of a subcontract, City assumes Contractor's rights and obligations under that subcontract. City may further assign the subcontract to a successor contractor but shall remain legally responsible for the successor contractor's obligations.

**(c) Equitable Adjustment.** If work under an assigned subcontract has been suspended for more than thirty (30) days following Contract termination, the Subcontractor's compensation shall be equitably adjusted for any increase in direct costs resulting from the suspension.

**(d) Production of Subcontract Documents.** Upon City's request at any time, Contractor shall promptly provide complete copies of all subcontract agreements, purchase orders, and related documents, including all terms, conditions, pricing, and delivery schedules.

### ARTICLE 3: CONTRACTOR LICENSES, PERMITS, AND REGULATORY COMPLIANCE

---

#### 3.1 North Carolina General Contractor License

Contractor warrants and certifies that it possesses a valid and current North Carolina General Contractor License issued by the North Carolina Licensing Board for General Contractors (NCLBGC) as required by N.C. Gen. Stat. § 87-1 et seq.

##### 3.1.1 License Classification

Contractor's license classification is: \_\_\_\_\_ (Building Contractor / Highway Contractor / Public Utilities Contractor / Specialty Contractor)

##### 3.1.2 License Limitation

Contractor's license limitation is: \_\_\_\_\_ (Limited — projects up to \$750,000 / Intermediate — projects up to \$1,500,000 / Unlimited — no monetary restrictions). Contractor certifies that the contract amount does not exceed the monetary limitation of its license.

##### 3.1.3 License Number and Qualifier

- North Carolina General Contractor License Number: \_\_\_\_\_
- Qualifying Party Name: \_\_\_\_\_
- Qualifier License Number: \_\_\_\_\_

### **3.1.4 Maintenance of License**

Contractor shall maintain its General Contractor License in good standing throughout the duration of this Contract. Contractor shall immediately notify the City of any suspension, revocation, or limitation placed on its license. Failure to maintain a valid license shall constitute a material breach of this Contract and grounds for immediate termination.

### **3.2 Specialty Trade Licenses**

In addition to the General Contractor License, Contractor shall ensure that all work requiring specialty trade licenses is performed by properly licensed contractors, including but not limited to:

**(a) Electrical Work:** All electrical work shall be performed by contractors licensed by the North Carolina Board of Examiners of Electrical Contractors;

**(b) Plumbing, Heating, and Fire Sprinkler Work:** All plumbing, HVAC, and fire sprinkler work shall be performed by contractors licensed by the North Carolina State Board of Examiners of Plumbing, Heating, and Fire Sprinkler Contractors;

**(c) Other Specialty Contractors:** All other specialty work shall be performed by appropriately licensed contractors as required by North Carolina law.

### **3.3 Corporate Registration Requirements**

**(a) In-State Corporations:** Contractor has provided proof of registration via Articles of Incorporation filed with the North Carolina Secretary of State;

**(b) Out-of-State Corporations:** Contractor has obtained and provided a Certificate of Authority from the Corporations Division of the NC Secretary of State to transact business in North Carolina;

**(c) Annual Reports:** Contractor agrees to maintain current corporate status by filing annual reports with the North Carolina Secretary of State as required by law.

### **3.4 Building Permits and Inspections**

Contractor shall obtain and pay for all building permits, trade permits, and other permits required by local, state, and federal authorities having jurisdiction. Contractor shall not commence work until all required permits have been obtained and posted at the work site. All permits shall be prominently displayed throughout the duration of construction. Copies of all inspections and permits shall be provided to FAST for record keeping. All work shall comply with the North Carolina State Building Code, all applicable local codes, and all applicable federal regulations.

### **3.5 Professional Registration**

Any design work, engineering work, or professional services required under this Contract shall be performed only by individuals or firms holding current registration/licensure with the appropriate North Carolina professional licensing boards, including the North Carolina Board of Architecture and the North Carolina Board of Examiners for Engineers and Surveyors.

### **3.6 Federal and State Tax Compliance**

Contractor certifies that it is current on all federal and state tax obligations and shall remain current throughout the duration of this Contract. Contractor shall provide evidence of tax compliance upon request by the City.

### **3.7 Lien Agent Registration (Projects Over \$40,000)**

For all projects with a contract amount exceeding \$40,000, Contractor shall comply with N.C. Gen. Stat. § 44A-11.1 by designating a lien agent and filing a Notice of Contract and Notice of Lien Agent Designation within fifteen (15) days of the effective date of this Contract, and providing the City with proof of filing.

### **3.8 Environmental Permits**

Contractor shall obtain all required environmental permits, including stormwater (NPDES), erosion and sediment control, air quality, wetlands, and any other environmental permits required by federal, state, or local authorities.

### **3.9 OSHA and Safety Compliance**

Contractor shall comply with all applicable OSHA regulations (29 C.F.R. Part 1926) and North Carolina Department of Labor safety requirements. Contractor shall maintain all required safety programs and documentation.

### **3.10 Right to Verify**

The City reserves the right to verify all licenses, permits, registrations, and certifications required under this Article. Failure to maintain any required license, permit, or certification shall constitute a material breach of this Contract.

### **3.11 Costs**

All costs associated with obtaining and maintaining licenses, permits, registrations, and certifications required under this Article shall be borne solely by Contractor and are deemed included in the Contract amount.

## **ARTICLE 4: INSURANCE REQUIREMENTS**

---

At all times during performance of services under this Contract, Contractor agrees to purchase and maintain the following insurance policies. Contractor shall secure the required insurance policies prior to performing any work and shall maintain such policies throughout the term of this Contract. In the event that any portion of Contractor's obligations are subcontracted, Contractor shall require each subcontractor to secure and maintain insurance satisfying the requirements of this Article, or alternatively, Contractor may secure and maintain such insurance on the subcontractor's behalf.

### **4.1 Commercial General Liability Insurance**

Commercial General Liability Insurance with combined single limits of \$1,000,000.00 coverage for each occurrence with a general aggregate of \$2,000,000.00, designating the City of Fayetteville and FAST as additional insureds. Said insurance coverage shall be underwritten by an insurance company authorized to do business in the State of North Carolina by the North Carolina Department of Insurance, with an A.M. Best rating of either Superior (A++ or A+) or Excellent (A or A-).

### **4.2 Automobile Liability Insurance**

Commercial automobile liability insurance with \$1,000,000.00 combined single limit for each accident covering bodily injury and property damage for owned, non-owned, and hired automobiles.

### **4.3 Workers' Compensation Insurance**

Workers' Compensation Insurance as provided by North Carolina law, with Coverage A Statutory – State of North Carolina and Coverage B Employers' Liability with limits of \$500,000 each accident

and policy limit, including occupational disease coverage. Contractor shall provide adequate coverage for the protection of employees not otherwise protected by a worker's compensation policy.

#### **4.4 Contractual Liability Insurance**

As an integral part of this Contract, Contractor agrees to purchase and maintain during the life of this Contract contractual liability insurance in the amount required in the general liability insurance requirements above and to furnish proper evidence thereof.

#### **4.5 Certificates of Insurance**

Before commencing performance under this Contract, for each required policy Contractor shall furnish a Certificate of Insurance (COI) to the City that demonstrates coverage in compliance with the requirements of this Article, naming City of Fayetteville and FAST as additional insureds, with effective and expiration dates of the policy and any exclusions. Each policy shall provide not less than thirty (30) days' written notice prior to cancellation. If any required coverage lapses for any reason, Contractor shall provide immediate written notice to the City.

### **ARTICLE 5: PAYMENT AND PERFORMANCE BONDS**

---

#### **5.1 Bond Requirements — FTA and State Thresholds**

**FTA Threshold (Governing for this Contract):** Because this Contract is funded in whole or in part with Federal Transit Administration financial assistance, performance and payment bonds are required on all construction contracts exceeding \$150,000, pursuant to 2 CFR § 200.325 and 49 U.S.C. § 5325. The FTA threshold governs and takes precedence over the state threshold for this federally-funded project.

**State Threshold:** Pursuant to N.C. Gen. Stat. § 44A-26, when the total amount of construction contracts awarded for any one project exceeds \$300,000, bonds are also required for any contract exceeding \$50,000.

##### **5.1.1 Performance Bond**

A performance bond in the amount of one hundred percent (100%) of the construction contract amount, conditioned upon the faithful performance of the contract in accordance with the plans, specifications, and the terms of this Contract. The performance bond shall be for the protection of the City and FAST and shall secure the faithful performance of all duties and obligations of Contractor under this Contract.

##### **5.1.2 Payment Bond**

A payment bond in the amount of one hundred percent (100%) of the construction contract amount, conditioned upon the prompt payment for all labor or materials for which Contractor or subcontractor is liable. The payment bond shall be solely for the protection of the persons furnishing materials or performing labor for which Contractor, subcontractor, or construction manager at risk is liable.

##### **5.1.3 Discretionary Bonds**

In the discretion of the City, performance and payment bonds may be required on construction contracts below the statutory threshold amounts.

#### **5.2 Surety Requirements**

All bonds shall be executed by one or more surety companies legally authorized to do business in the State of North Carolina and shall become effective upon the awarding of the construction contract. All surety companies shall maintain an A.M. Best rating of either Superior (A++ or A+) or Excellent (A or A-).

### **5.3 Bond Forms**

The payment and performance bonds required under this Contract shall follow the forms established under N.C. Gen. Stat. § 44A-33. Bond forms are attached as Exhibit 4.

### **5.4 Certified Copies of Bonds**

It shall be the duty of the City to provide any person entitled thereto under N.C. Gen. Stat. § 44A-31 with a certified copy of the payment bond and the construction contract upon not less than ten (10) days' notice and request. The City may require a reasonable payment for the actual cost of furnishing the certified copy.

### **5.5 Contractor's Duty to Provide Bond Copies**

Contractor shall furnish a copy of the payment bond to any claimant within seven (7) days of receipt of a written request, as required by N.C. Gen. Stat. § 44A-27(b). Failure to furnish the bond as requested shall suspend the obligation of the subcontractor to furnish the Notice of Public Subcontract until the request is complied with.

### **5.6 Incorporation of Contract Documents**

It is agreed and understood that the Invitation to Bid, Bid Form, Price Sheet, Attachments A through O (including FTA Requirements), all issued Addenda by number, Exhibit 1 (Proposal/Bid), Exhibit 2 (Addendum Acknowledgment), Exhibit 3 (Special Provisions and Specifications), and this Contract Agreement are parts and parcels of this Contract to the same extent as if incorporated herein in full.

### **5.7 Additional Security**

It is further mutually agreed that if at any time after the execution of this Agreement and the surety bonds, City shall deem the surety or sureties upon such bonds to be unsatisfactory, or if, for any reason, such bonds cease to be adequate to cover performance and payment of the work, Contractor shall, at its expense, within five (5) days after the receipt of notice, furnish an additional bond or bonds in such form and amount, and with such surety or sureties as shall be satisfactory to City. In such event, no further payment to Contractor shall be deemed to be due under this Agreement until such new or additional security for the faithful performance of the work shall be furnished in manner and form satisfactory to City.

## **ARTICLE 6: TIME OF COMPLETION AND LIQUIDATED DAMAGES**

---

### **6.1 Contract Time**

Contractor agrees to commence work under this Contract on the date specified in the Notice to Proceed issued by the City and to complete all work within **seventy-five (75) calendar days** from said date, or by the date specified in the Notice to Proceed, whichever occurs first. Time is of the essence in the performance of this Contract.

### **6.2 Substantial Completion**

Substantial Completion shall mean the stage in the progress of the work when the work or designated portion thereof is sufficiently complete in accordance with the Contract Documents so

that the City can occupy or utilize the work for its intended use. The date of Substantial Completion shall be established by the City in the Certificate of Substantial Completion and, where applicable, supported by a Temporary Certificate of Occupancy (TCO).

### **6.3 Liquidated Damages for Delay**

The parties acknowledge and agree that: (a) the actual damages that the City will sustain in the event of delay are difficult to ascertain with certainty; (b) the liquidated damages amount set forth herein represents a reasonable pre-estimate of damages which would probably be caused by breach of the completion deadline and are not intended as a penalty; and (c) the liquidated damages include but are not limited to costs associated with extended project administration, extended oversight and inspection services, delay in availability of the bus stop and sidewalk facilities for FAST transit riders, and other consequential damages reasonably anticipated from delayed completion.

Accordingly, if Contractor fails to achieve Substantial Completion within the time specified in Section 6.1, Contractor shall pay to the City, not as a penalty but as liquidated damages for breach of contract, the sum of **\$1,000.00** for each calendar day that Substantial Completion is delayed beyond the required completion date.

### **6.4 Deduction of Liquidated Damages**

The City may deduct the amount of liquidated damages from any amounts due or to become due to Contractor under this Contract. The City's right to assess and collect liquidated damages shall not be exclusive and shall be in addition to any other rights or remedies available to the City under this Contract or at law.

### **6.5 Extensions of Time**

Contractor shall be entitled to an extension of the Contract Time for delays in completion of the work caused by: (a) acts or omissions of the City or its agents; (b) changes in the work ordered by the City; (c) unusually severe weather conditions not reasonably anticipated; (d) force majeure events as defined in Section 31.2; (e) delays caused by labor disputes beyond Contractor's control; (f) delays caused by fire, flooding, epidemics, quarantine restrictions, or acts of government; or (g) any other causes beyond the reasonable control of Contractor and not attributable to Contractor's fault or negligence.

### **6.6 Procedure for Requesting Time Extensions**

Contractor shall submit a written request for extension of time to the City within ten (10) calendar days after the occurrence of the event causing the delay. The request shall include a description of the cause of delay, the date commenced, anticipated duration, documentation supporting that the delay was beyond Contractor's control, number of days of extension requested, and any supporting contemporaneous records and correspondence. Failure to provide timely notice may result in waiver of the claim unless the City determines circumstances prevented timely notice.

### **6.7 Apportionment of Concurrent Delays**

In the event that delays are caused by both the City and Contractor, liquidated damages shall be apportioned based upon their respective degrees of responsibility for the delays. The burden of proving the extent and allocation of concurrent delays shall rest with Contractor. This apportionment provision is essential to the enforceability of the liquidated damages clause and is included in accordance with North Carolina law.

### **6.8 No Waiver**

The City's failure to assess liquidated damages for any period of delay shall not constitute a waiver of the City's right to assess liquidated damages for any other period of delay or for continued delays.

## **6.9 Final Completion**

Final Completion shall occur when all work under the Contract is fully completed in accordance with the Contract Documents, all required documentation has been submitted, all punch list items have been completed, and the City has accepted the work as complete.

# **ARTICLE 7: SMALL BUSINESS, DISADVANTAGED BUSINESS ENTERPRISE, AND DIVERSITY PROGRAMS**

---

## **7.1 Dual Program Requirements**

Because this Contract is funded in whole or in part with FTA financial assistance, Contractor is subject to two distinct but complementary programs: (a) the Federal Disadvantaged Business Enterprise (DBE) program under 49 C.F.R. Part 26, as amended; and (b) the City of Fayetteville's local Small/Disadvantaged Business Enterprise (SDBE) Program established under the City's Charter, as amended by the General Assembly (H.B. 198). Both programs apply independently and compliance with one does not constitute compliance with the other.

## **7.2 Federal DBE Program Compliance — October 3, 2025 Interim Final Rule**

Effective October 3, 2025, USDOT removed race- and sex-based presumptions of social and economic disadvantage from the DBE program (Docket No. DOT-OST-2025-0897). All DBE participation must now be based on individualized determinations without regard to race or sex.

### **7.2.1 Current Certification Requirements**

Any DBE firm utilized must: (a) provide individualized proof of social and economic disadvantage based on the owner's personal experiences and circumstances, without regard to race or sex; (b) submit a personal narrative establishing existence of disadvantage based on specific instances of economic hardship, systemic barriers, and denied opportunities; (c) be currently certified through the North Carolina Unified Certification Program (NCUCP) or other applicable state or regional Unified Certification Program (UCP); and (d) comply with personal net worth and business size standards as established in 49 C.F.R. Part 26.

### **7.2.2 Recertification Process**

All previously certified DBE firms are subject to mandatory reevaluation and recertification under the new individualized standards. Until a DBE firm completes recertification: (a) the firm's participation may not be counted toward DBE goals on new contracts; (b) Contractor bears the risk of utilizing firms whose certifications may be decertified during the reevaluation process; and (c) Contractor must verify current certification status with the NCUCP before executing subcontracts with DBE firms.

### **7.2.3 DBE-Neutral and DBE-Conscious Measures**

The City's DBE program will utilize DBE-neutral measures to the maximum extent feasible before implementing any DBE-conscious contract goals. Contractor shall assist in facilitating DBE participation through race-neutral methods during the transition period.

## **7.3 Contract-Specific DBE Goal**

If a specific DBE participation goal has been established for this Contract, that goal is: \_\_\_\_%. Contractor must meet this goal through one or more of the following methods: (a) subcontracting a portion of the work to qualified, certified DBE firms; (b) demonstrating good faith efforts as defined in 49 C.F.R. § 26.53; or (c) obtaining a waiver from the City based on documented unavailability of qualified DBE firms.

#### **7.4 Good Faith Efforts**

If Contractor is unable to meet the stated DBE goal, Contractor must demonstrate adequate good faith efforts, including but not limited to:

- Soliciting through all reasonable and available means the interest of certified DBE firms;
- Attending pre-bid meetings to inform DBEs of contracting and subcontracting opportunities;
- Providing interested DBEs with adequate information about plans, specifications, and requirements of the Contract to allow them to respond to the solicitation, including timely follow-up with interested DBEs;
- Negotiating in good faith with interested DBEs and not rejecting DBEs as unqualified without sound reasons based on a thorough investigation of their capabilities;
- Making portions of the work available to DBE firms, including breaking down contracts into economically feasible units to facilitate DBE participation;
- Providing assistance in obtaining required bonding, lines of credit, or insurance required by the City or Contractor;
- Effectively using services of available business assistance organizations, minority community organizations, and contractors' groups to locate and recruit DBE firms.

#### **7.5 Local SDBE Program**

The City of Fayetteville aspires to spend 40% of its eligible contract dollars with small local suppliers and contractors located in Cumberland and Hoke Counties. Contractor shall make good faith efforts to utilize certified SDBE firms and shall comply with all SDBE program requirements, goal percentages, documentation requirements, and affidavit forms established in the ITB for this project.

##### **7.5.1 NC SBE Programs (If Applicable)**

For projects administered in coordination with the North Carolina Department of Transportation, businesses with annual gross income exceeding \$1,500,000 (exclusive of materials) are not eligible to participate as SBEs under the NCDOT SBE Program.

##### **7.5.2 Statewide NCSBE Program (If Applicable)**

For projects subject to the NC Department of Administration's Statewide Small Business Enterprise (NCSBE) Program, eligible businesses must: (a) be headquartered in North Carolina; (b) have annual net income not exceeding \$1,500,000 after cost of goods sold is deducted; (c) have up to 100 employees; and (d) maintain current NCSBE certification through the NC Office for Historically Underutilized Businesses (HUB).

#### **7.6 Counting DBE/SDBE Participation**

DBE and SDBE participation will be counted in accordance with the provisions of 49 C.F.R. § 26.55 and applicable City SDBE program rules. Only the work actually performed by certified firms using their own employees, or work that the firm is directly responsible for, will count toward meeting goals. In determining achievement of goals, the participation of a DBE/SDBE shall not be counted until that amount has been paid to the DBE/SDBE.

## **7.7 Commercially Useful Function**

A DBE or SDBE performs a commercially useful function when it is responsible for execution of the work and actually performs, manages, and supervises the work involved with its own forces. To count toward DBE/SDBE goals, the firm must be responsible for materials and supplies used on the Contract, for negotiating the price, determining quality and quantity, ordering the material, and paying for the material itself. A DBE/SDBE does not perform a commercially useful function if its role is limited to that of an extra participant in a transaction through which funds are passed in order to obtain the appearance of DBE/SDBE participation.

## **7.8 Reporting and Record-Keeping**

Contractor shall: (a) submit DBE/SDBE utilization reports with each monthly payment application, documenting actual payments made to DBE/SDBE subcontractors; (b) maintain records demonstrating payments to DBE/SDBE firms for three (3) years following final project completion; (c) provide copies of executed subcontracts and evidence of payment upon City request; and (d) immediately notify the City if a DBE/SDBE firm is terminated or fails to perform, and document good faith efforts to replace the firm with another qualified DBE/SDBE.

## **7.9 Prohibition Against Discrimination**

Contractor shall not discriminate on the basis of race, color, national origin, or sex in the performance of this Contract. Contractor shall carry out applicable requirements of 49 C.F.R. Part 26 and NCGS § 143-128.2 in the award and administration of this Contract. Failure to carry out these requirements is a material breach that may result in termination of this Contract or such other remedy as the City deems appropriate.

## **7.10 Prompt Payment to Subcontractors**

Contractor agrees to pay all subcontractors, including DBE and SDBE subcontractors, for satisfactory performance no later than thirty (30) days from Contractor's receipt of payment from the City, pursuant to 49 C.F.R. § 26.29 and N.C. Gen. Stat. § 143-134.1. Any delay or postponement of payment must be for good cause and with the City's prior written approval. Contractor further agrees to return retainage payments to subcontractors within thirty (30) days after the subcontractor's work is satisfactorily completed and accepted.

## **7.11 Substitution of DBE/SDBE Firms**

Contractor shall not terminate or substitute a DBE or SDBE firm listed in the original proposal without the City's prior written consent. Requests for substitution must include: (a) documentation of good cause for the requested substitution; (b) written notice provided to the DBE/SDBE firm with an opportunity to respond; and (c) documentation of good faith efforts to find an acceptable replacement DBE/SDBE firm, if applicable.

## **7.12 Sanctions for Non-Compliance**

Failure to comply with DBE/SDBE requirements may result in: (a) withholding of progress payments; (b) suspension or termination of the Contract; (c) debarment from future City contracts; and (d) such other remedies as may be available under federal or state law.

## **7.13 Federal Funding Acknowledgment**

Because this Contract is funded in whole or in part with federal funds, Contractor acknowledges that federal DBE requirements take precedence over state and local requirements to the extent of any conflict, and that the City's DBE program operates in compliance with USDOT requirements.

## **ARTICLE 8: NON-DISCRIMINATION**

---

It is further agreed that the Contractor will not discriminate against any employee or applicant because of race, color, creed, sex, age, disability, or religion in the performance of this Contract. Contractor shall comply with all applicable federal and state non-discrimination requirements including those set forth in Article 17.

### **8.1 Terminating Illegal Discrimination Certification (Federally Funded Projects)**

Contractor certifies that: (i) it does not operate any DEI programs that violate any applicable Federal anti-discrimination laws; (ii) it is compliant in all respects with all applicable Federal anti-discrimination laws material to the government's payment decisions; and (iii) agrees that, if a violation of this certification is found, it could lead to liability under the False Claims Act. By signing this Agreement, Contractor further agrees, as an independent obligation separate and apart from this Agreement, to reimburse the City for any and all damages, costs and attorneys' fees incurred by the City in connection with any claim that this Agreement or any part thereof is void due to Contractor's noncompliance with this certification at any time before or during the term of this Agreement.

## **ARTICLE 9: CHANGE ORDERS AND CONTRACT MODIFICATIONS**

---

### **9.1 Authority to Order Changes**

The City reserves the right to order changes in the work without invalidating this Contract. Changes in the work may include additions, deletions, or other revisions to the work, with the Contract Sum and Contract Time being adjusted accordingly.

### **9.2 Change Order Procedure**

#### **9.2.1 Written Authorization Required**

No changes to the work shall be made unless authorized by a written Change Order Request Form signed by the City. Contractor shall not proceed with any change in the work without such written authorization. Any work performed without a fully executed Change Order Request Form shall be at Contractor's sole risk and expense. A Change Order Request Form example is attached as Exhibit 9.

#### **9.2.2 Change Order Request**

Contractor shall submit a Change Order Request Form within ten (10) calendar days of being directed to perform changed work or within ten (10) calendar days of discovering conditions requiring a change. The request shall include: (a) detailed description of the proposed change; (b) itemized cost breakdown including labor by classification, materials, equipment, overhead, and profit; (c) impact on project schedule with critical path analysis; (d) supporting documentation (quotes, invoices, time records); and (e) justification for the change.

#### **9.2.3 Pricing of Changes**

Changes in the work shall be priced using one or more of the following methods, in order of preference: (a) Lump Sum — a mutually agreed upon fixed price; (b) Unit Prices — application of unit prices specified in the Contract Documents or as mutually agreed upon; (c) Cost Plus — actual costs plus a markup not to exceed fifteen percent (15%) for overhead and profit. Actual costs shall be substantiated by documentation satisfactory to the City.

#### **9.2.4 Markup Limitations**

- Contractor's own work: 15% for overhead and profit combined
- Subcontractor work: Subcontractor may markup 15%; Contractor may add maximum 10% on subcontractor's cost
- No markup shall be applied to sales tax, permits, fees, or City-designated allowance items

### **9.2.5 Time Extensions**

If a Change Order affects the Contract Time, Contractor must request a time extension in writing with supporting documentation showing critical path impact. Time extensions shall be granted only for delays to critical path activities.

### **9.3 Minor Changes**

The City may authorize minor changes in the work that do not involve a change in the Contract Sum or Contract Time through written directive. Contractor shall proceed promptly with such minor changes.

### **9.4 Construction Change Directives**

If the City and Contractor cannot agree on pricing or time for a change, the City may issue a Construction Change Directive ordering Contractor to proceed. Contractor shall proceed promptly, and the Change Order shall be resolved through one of the pricing methods in Section 9.2.3.

### **9.5 Concealed or Unknown Conditions**

If Contractor encounters concealed or unknown conditions at the site materially differing from those indicated in the Contract Documents or from those ordinarily encountered in work of this nature, Contractor shall immediately notify the City in writing before disturbing the condition. Failure to provide timely notice may result in waiver of any claim for additional compensation.

### **9.6 Claims for Additional Cost**

Any claim for additional cost must be submitted in writing within ten (10) calendar days after occurrence of the event giving rise to the claim. Claims submitted after ten (10) days may be denied as untimely. Each claim shall include detailed supporting documentation.

### **9.7 No Oral Modifications**

No oral statements, representations, or agreements shall modify or change any provision of this Contract. All modifications must be in writing and signed by authorized representatives of both parties.

## **ARTICLE 10: PAYMENT PROVISIONS**

---

### **10.1 Schedule of Values**

Within fifteen (15) days of Contract execution, Contractor shall submit a Schedule of Values allocating the entire Contract Sum among the various portions of the work on forms provided by the Engineer. The Schedule of Values shall:

- Divide each line item into installation and materials cost components;
- Include no individual installation cost line item exceeding \$50,000; items not subdivided into smaller units may only be included in an Application for Payment when Work on the entire unit is complete;

- Distribute Contractor's overhead and profit proportionally across all line items in proportion to the value of each item to the Contract Sum — not as a separate standalone line item;
- Lump sum items may be divided into an estimated number of units to estimate earned value; the estimated number of units times the cost per unit must equal the lump sum amount for that line item;
- Include a breakdown of both mobilization and demobilization costs separately;
- Be approved in writing by the Surety Company providing performance and payment bonds ("Consent of Surety Company to Payment Procedures") before the first Application for Payment is submitted;
- Be approved by the Engineer before any Application for Payment is submitted.

## 10.2 Monthly Payment Applications

### 10.2.1 Submission Requirements

Contractor shall submit a draft Application for Payment to the Engineer on the twenty-fifth (25th) day of each month for work completed through the last day of the previous month. Applications shall not be submitted more often than monthly unless approved by the City. Contractor shall review the draft with the Engineer prior to formal submission. Each Application for Payment shall include:

- Updated Schedule of Values showing percentage complete for each line item with earned value;
- NC Sales Tax Affidavit certifying sales tax paid on materials (required beginning with first application; required even if no taxable items, certifying that fact);
- Copies of paid invoices for materials stored on-site;
- Waivers of lien from subcontractors and suppliers;
- DBE/SDBE utilization report showing actual payments made to DBE/SDBE subcontractors;
- Weekly certified payrolls (Davis-Bacon compliance — Form WH-347 or equivalent);
- Updated red-line record drawings for the payment period;
- Updated Construction Progress Schedule showing progress to closing date;
- **Attachment A** — Tabulation of Earned Value of Original Contract Performed (materials stored and incorporated; earned value for installation by line item);
- **Attachment B** — Tabulation of Values for Materials and Equipment (invoices supporting materials amounts requested, allocated to line items);
- **Attachment C** — Summary of Set-offs (each set-off applied, with corresponding reductions when released);
- **Attachment D** — Retainage Calculation (method of calculation; any request for reduction must be accompanied by Consent of Surety to Reduction or Partial Release of Retainage);
- **Attachment E** — Earned Value Analysis (EVA) Chart — graphic representation comparing anticipated cumulative earned value to actual cumulative earned value month by month; adjusted to incorporate Modifications.

### 10.2.2 Stored Materials

Materials suitably stored on-site may be included in progress payments if: materials are properly stored and protected; Contractor provides proof of payment to supplier; Contractor provides evidence of insurance covering stored materials; and City approves inclusion in advance. Materials stored off-site shall not be eligible for payment unless specifically approved in writing by the City.

## **10.3 Retainage**

### **10.3.1 Standard Retainage**

The City shall retain five percent (5%) of the amount of each progress payment as security for Contractor's performance.

### **10.3.2 Reduction of Retainage**

Upon fifty percent (50%) completion of the work, and if the City determines that progress is satisfactory, the City may reduce or eliminate retainage on subsequent progress payments. Any request for reduction must be accompanied by a Consent of Surety to Reduction or Partial Release of Retainage.

### **10.3.3 Release of Retainage Upon Substantial Completion**

Upon Substantial Completion of the work, the City may release all or a portion of retainage, less an amount sufficient to cover the estimated cost of completing punch list items and correcting any deficiencies.

### **10.3.4 Subcontractor Retainage**

Contractor shall return retainage to subcontractors within thirty (30) days after the subcontractor's work is satisfactorily completed and accepted, in accordance with N.C. Gen. Stat. § 143-134.1 and 49 C.F.R. § 26.29. Unless there are specific documented reasons for withholding retainage, failure to return retainage within this period may result in withholding of future payments to Contractor.

## **10.4 Payment Timeline**

The City shall make payment within thirty (30) days after receipt of a properly submitted and Engineer-approved Application for Payment. Final payment shall require City Council approval and may take longer than thirty (30) days.

## **10.5 Withholding of Payment**

The City may withhold or nullify payment, in whole or in part, to the extent necessary to protect itself from loss due to any of the following:

- Defective work not remedied;
- Claims filed or reasonable evidence that claims will be filed;
- Failure to make payments to subcontractors or suppliers;
- Reasonable doubt that the Contract can be completed for the unpaid balance;
- Damage to the City, FAST, or another contractor;
- Reasonable evidence that work cannot be completed within Contract Time;
- Repeated failure to carry out work in accordance with Contract Documents;
- Failure to submit current Construction Progress Schedule;
- Failure to submit monthly updated red-line record drawings;
- DBE/SDBE utilization report not submitted or not current;
- Davis-Bacon certified payrolls not current or not submitted;
- Failure to submit required EVA Chart or required Attachments A through E;
- Non-compliance with FTA or other federal requirements;
- Any other material breach of Contract.

## **10.6 Interest on Late Payments**

Pursuant to N.C. Gen. Stat. § 143-134.1, if the City fails to make payment within the time specified in Section 10.4 and through no fault of Contractor, the City shall pay interest on the unpaid amount at the rate of twelve percent (12%) per annum from the date payment is due until payment is made.

## **10.7 Prompt Payment to Subcontractors**

Pursuant to N.C. Gen. Stat. § 143-134.1, Contractor shall pay each subcontractor and supplier within seven (7) days of receipt of payment from the City for work performed by that subcontractor or for materials supplied. If Contractor fails to make timely payment, Contractor shall pay interest to the subcontractor or supplier at the rate of twelve percent (12%) per annum on the unpaid amount. Failure to make prompt payment may result in withholding of future payments to Contractor.

## **10.8 Final Payment**

Upon completion of all work, Contractor shall submit a final Application for Payment including all closeout documentation required by Article 16. Final payment shall be made within thirty (30) days after completion of all work and receipt of all required documentation, subject to City Council approval. Acceptance of final payment shall constitute a waiver of all claims by Contractor except those previously made in writing and still unsettled.

# **ARTICLE 11: PROJECT SCHEDULE AND TIME MANAGEMENT**

---

## **11.1 Construction Schedule Submission**

Contractor shall submit a preliminary Construction Progress Schedule at the Pre-Construction Conference and a detailed schedule at least ten (10) days prior to the first Application for Payment. The schedule shall be in Critical Path Method (CPM) format showing all activities, sequential relationships and dependencies, duration of each activity, single critical path, major milestones and completion dates, long-lead procurement items, required submittal and shop drawing dates, and coordination with other contractors or occupants if applicable.

## **11.2 Schedule Format and Software**

The schedule shall be prepared using industry-standard scheduling software (Primavera P6, Microsoft Project, or as approved by City) by personnel with five (5) years' minimum experience in scheduling comparable construction work. Submit in both electronic native format and PDF. Contractor assumes complete responsibility for maintaining progress per the schedule.

## **11.3 Monthly Schedule Updates**

Contractor shall submit updated schedules monthly with each Application for Payment. Applications for Payment will not be recommended for payment without a current Progress Schedule. If the Project falls more than thirty (30) days behind schedule, Contractor shall submit a Plan of Action including: number of days behind schedule; narrative description of steps to be taken to bring the Project back on schedule; and anticipated time required to achieve recovery. Submit a revised Progress Schedule with the Plan of Action.

## **11.4 Near-Term Look Ahead (NTLA) Schedules**

Contractor shall provide a Near-Term Look Ahead (NTLA) Schedule every fourteen (14) days at periodic coordination meetings, showing: submittals to be provided and anticipated return; equipment and material deliveries; arrival and departure of key construction equipment; and activities for the Contractor and each Subcontractor. Contractor shall submit a report identifying

deviations from the Project Schedule with each NTLA Schedule and a report of near-term work planned in the previous NTLA Schedule that was delayed or not executed.

### **11.5 Float Time**

Float time is not for the exclusive use or benefit of either the Contractor or Owner. Contract Times cannot be changed by submission of a Progress Schedule; Contract Times can only be modified by a Change Order or Contract Amendment.

### **11.6 Notice to Proceed**

Contractor shall not commence work until receiving written Notice to Proceed from the City. The Contract Time shall commence on the date specified in the Notice to Proceed.

### **11.7 Traffic Control Plan**

Contractor shall submit a Traffic Control Plan to the City of Fayetteville Traffic Engineer within fourteen (14) days of being declared the lowest responsible bidder. No work shall begin until all traffic control devices required for the particular work activity have been installed, inspected, and approved by the City of Fayetteville Traffic Engineer or their representative. Approval is required for any intended street closures at least five (5) working days in advance. No public roads shall be closed overnight without written permission from the City of Fayetteville Traffic Engineer. Contractor shall comply with the City of Fayetteville's Truck Route Ordinance.

## **ARTICLE 12: SUBMITTALS, SHOP DRAWINGS, AND PRODUCT DATA**

---

### **12.1 Submittal Requirements**

Contractor shall submit shop drawings, product data, samples, and other submittals as required by the Contract Documents for review and approval before procuring materials, fabricating components, or commencing any portion of work requiring submittals.

### **12.2 Submittal Schedule**

Contractor shall submit a Schedule of Documents at the Pre-Construction Conference, coordinated with the construction schedule, listing each required submittal with anticipated submission date and required review time. Assume a fourteen (14)-day review cycle for each submittal unless otherwise specified. Allow time for making revisions and resubmitting for at least a second review.

### **12.3 Submittal Procedures**

#### **12.3.1 Format and Content**

All submittals shall: (a) be clearly marked with project name, submittal number, and specification section; (b) highlight deviations from Contract Documents; (c) include manufacturer's data and certifications; (d) be submitted in Portable Document Format (PDF); and (e) include Contractor's stamp of review and approval indicating Contractor has verified dimensions and quantities.

#### **12.3.2 Review Time**

The City/Engineer shall be allowed fifteen (15) business days for review of submittals unless a different time is specified. Review time shall be calculated from receipt of properly formatted submittals. Incomplete or incorrectly formatted submittals will be returned without review.

#### **12.3.3 Resubmittals**

If submittals are rejected or require revision, Contractor shall make corrections and resubmit within ten (10) days. Each resubmittal restarts the review period. Contractor is responsible for all delays associated with additional review time required for incomplete or erroneous documents.

## **12.4 Substitutions**

Substitutions require a formal Change Proposal submitted to the Engineer with documentation required for a Shop Drawing. Contractor bears the burden of proving the substitute product is acceptable on a point-by-point basis against each specified feature. The Engineer's decision is final. Contractor shall certify that the substituted product will perform in substantially the same manner, provide the same warranties, and maintain the same time schedule.

## **12.5 City Review**

City/Engineer review of submittals is for general conformance with design concept only. Review does not: (a) relieve Contractor of responsibility for errors or omissions; (b) constitute approval of means, methods, or safety procedures; (c) relieve Contractor of responsibility for dimensions or quantities; or (d) constitute acceptance of deviations unless specifically noted in writing.

## **12.6 Samples**

When required, Contractor shall submit samples for City approval before purchasing or installing materials. Approved samples shall be retained at the site for comparison with installed work.

# **ARTICLE 13: SITE MANAGEMENT AND WORKING CONDITIONS**

---

## **13.1 Site Access and Control**

### **13.1.1 Site Possession**

Upon issuance of Notice to Proceed, Contractor shall have full possession of the site except for portions specifically excluded in the Contract Documents. The City reserves the right to occupy portions of the work during construction.

### **13.1.2 Site Security**

Contractor shall: (a) maintain site security to prevent unauthorized access; (b) provide temporary fencing if required; (c) be responsible for loss or damage to materials and equipment; and (d) maintain control of all personnel on site.

## **13.2 Construction Signs**

Contractor shall provide and maintain project signage as required by the City, including: (a) project identification signs per City specifications; (b) safety and warning signs as required by OSHA; (c) traffic control signs as required by permits; and (d) "No Trespassing" signs if required.

## **13.3 Working Hours**

### **13.3.1 Standard Hours**

Normal working hours shall be Monday through Friday, 7:00 AM to 5:00 PM, unless otherwise specified or approved by the City. Contractor shall notify the Engineer at least seventy-two (72) hours in advance of intent to work outside regular working hours.

### **13.3.2 After-Hours Work**

Work outside normal hours, on weekends, or holidays requires prior written approval from the City. Contractor shall notify affected neighbors and coordinate with City police if required.

### **13.3.3 Noise Restrictions**

Contractor shall comply with all local noise ordinances and minimize disturbance to neighboring properties and City operations.

### **13.4 Parking and Staging**

Contractor shall provide adequate parking for all personnel, equipment, and vehicles in designated areas only. Parking on City streets or neighboring properties requires prior approval. Materials shall be stored in orderly fashion and shall not obstruct access or traffic. Traffic control plans require City approval before implementation. Contractor shall obtain written permission of the property owner before entering privately-owned land outside of the Owner's property, rights-of-way, or easements.

### **13.5 Site Conditions and Cleanliness**

#### **13.5.1 Daily Cleanup**

Contractor shall maintain the site in clean, safe condition at all times. Debris and waste shall be removed from the site regularly and disposed of properly. All debris must be maintained within the site perimeter. Any debris, soil, or sediment leaving the site must be cleaned immediately. Contractor shall comply with all Erosion and Sedimentation Control plans and clean sediment transported onto roadways at the end of each day by shoveling or sweeping before any street washing.

#### **13.5.2 Final Cleanup**

Before requesting Substantial Completion, Contractor shall: (a) remove all debris, rubbish, and waste materials; (b) clean all surfaces; (c) remove stains, marks, and dirt from all finished surfaces; (d) leave the site in "broom clean" condition; and (e) remove all construction signage and temporary facilities.

### **13.6 Protection of Existing Facilities**

Contractor shall protect existing structures, utilities, vegetation, and improvements from damage. Any damage shall be repaired or replaced at Contractor's expense to the City's satisfaction. Contractor shall not close or obstruct roads, pedestrian walks, or access to properties without prior approval, and shall construct and maintain at its expense any necessary ramps, boardwalks, or other means to maintain pedestrian traffic.

### **13.7 Utility Coordination**

#### **13.7.1 NC 811 Requirements**

Before commencing any excavation, Contractor shall: (a) contact NC 811 at least three (3) business days in advance; (b) mark proposed excavation areas with white paint; (c) maintain locate marks throughout construction; and (d) re-notify if work extends beyond original locate dates. Contractor shall contact all affected utility owners a minimum of forty-eight (48) hours prior to commencement of operations.

#### **13.7.2 Utility Protection**

Contractor shall: (a) protect all existing utilities from damage; (b) support and maintain utilities during construction; (c) coordinate shutdowns with City and affected utility companies; (d) provide temporary utilities as needed; and (e) immediately report any utility damage to City and utility

owner. In the event any utility service is interrupted, Contractor shall notify the utility owner immediately and cooperate in restoration of service in the shortest time possible.

### **13.7.3 Utility Damage**

Contractor shall be responsible for all costs associated with repair of damaged utilities. No additional compensation will be allowed for delays or inconvenience due to utility relocations or adjustments. If the Work is delayed as a result of damage to an improperly marked utility, Contractor may request an extension of Contract Time. If Work is delayed as a result of damage to a properly marked utility, no additional Contract Time or compensation shall be granted.

### **13.8 Construction Staking**

The City of Fayetteville Public Services Department (910-433-1656) shall perform all construction staking during normal business hours, Monday through Friday. Contractor shall give at least forty-eight (48) hours' notice prior to requiring staking or re-staking. Stakes knocked out by Contractor will be replaced by the Public Services Department at a charge to the Contractor of \$5.00 per stake. Control points or benchmarks damaged, disturbed, or destroyed as a result of Contractor's negligence shall result in a minimum charge of \$15.00 for replacing P.C. points and \$50.00 for replacing monuments.

### **13.9 Conduct of Contractor's Employees**

The following rules apply to all Contractor and Subcontractor employees on the Site:

- Alcoholic beverages and illegal substances are strictly prohibited. Persons on Site under the influence shall be permanently prohibited from returning. Criminal or civil penalties may also apply.
- Offensive language and sexual harassment in any form are prohibited and will cause immediate and permanent removal of the offender from the premises.
- Workers shall wear clothing that meets safety requirements. Sleeveless shirts, shorts, or excessively torn, ripped, or soiled clothing are not permitted.
- The following prohibited items are not allowed anywhere on the Site: firearms (including air rifles, pistols, and BB or pellet guns) and ammunition; bows, crossbows, arrows, bolts, or any other projectile weapons; explosives of any kind, including fireworks; illegal knives; and any other item designed or intended to be used as a weapon. No exception shall be made for any person possessing a valid state-issued license to carry a firearm. Any person found in possession of a prohibited item shall be immediately and permanently removed from the Site and may be reported to local law enforcement.

### **13.10 Public Convenience and Safety**

Contractor shall conduct operations to minimize inconvenience to the public and shall: (a) maintain access to all properties and storefronts; (b) provide temporary walkways and barriers; (c) coordinate deliveries to minimize traffic impact; (d) provide flaggers for traffic control as needed; and (e) maintain emergency vehicle access and fire hydrant access at all times. Contractor shall cooperate with the public and merchants affected by operations and maintain good public relations at all times.

### **13.11 Air Pollution Watch Days (APWD)**

During the ozone season (May 1 through October 31), state or local environmental agencies may designate Air Pollution Watch Days by 3:00 PM on the prior afternoon. On designated APWDs, Contractor shall not begin operations requiring heavy construction equipment for run times in excess of one (1) hour before 10:00 AM. Heavy construction equipment may be used before 10:00

AM if the equipment is certified by EPA as "Low Emitting" or burns Ultra Low Sulfur Diesel (ULSD), diesel emulsions, or alternative fuels such as CNG.

### **13.12 Archaeological Finds**

Contractor shall cease operations immediately and contact the Engineer if historical or archaeological artifacts are found during construction. Contractor shall: maintain confidentiality regarding the site(s) of artifacts; obtain the services of a qualified archaeological specialist; coordinate construction activities to permit archaeological work to take place; adhere to requirements of applicable local, state, and federal laws and regulations; and notify the City, the Engineer, and any local, state, or federal agency as required. Contract Times shall be modified to compensate for delays caused by such finds. No additional compensation will be paid for delays.

### **13.13 Endangered Species**

Contractor shall not perform any activity likely to destroy or adversely modify the habitat of any threatened or endangered species listed under the Federal Endangered Species Act (ESA) or applicable North Carolina law. If a threatened or endangered species is encountered during construction, Contractor shall immediately cease work in the area of the encounter and notify the Engineer. Construction in the area shall resume only when authorized by the Engineer. Contract Times shall be modified for delays caused by such encounters. No additional compensation will be paid for delays.

### **13.14 Blasting**

Blasting is not allowed for any purpose.

## **ARTICLE 14: QUALITY CONTROL AND TESTING**

---

### **14.1 Contractor's Quality Control Plan (CQCP)**

Contractor shall submit a CQCP to the Engineer as Product Data before beginning any Work. Work shall not commence until the CQCP is accepted. Contractor shall meet with the City seven (7) days after CQCP submission and before start of construction to discuss the plan. The CQCP shall include:

- Quality control organization chart showing lines of authority to control the quality of Work;
- Name, qualifications (in resume format), duties, responsibilities, and level of authority of a designated Quality Control Manager with authority to reject Defective Work, redirect Contractor's and Subcontractors' efforts to correct Defective Work, and implement steps to prevent future Defective Work;
- Testing and inspection procedures for each specific definable work task including name of tests, specification paragraph requiring the test, parameters of Work to be tested, test frequency, persons responsible, and applicable testing standards and laboratory facilities;
- Name and qualifications of the proposed Construction Materials Inspection and Testing (CMIT) provider, which must comply with American Council of Independent Laboratories (ACIL) standards;
- Reporting procedures incorporating use of forms provided by the Engineer;
- Procedures for tracking and documenting quality management efforts.

### **14.2 Three-Phase Quality Control**

For each definable work task — a task that is separate and distinct, has separate control requirements, may be provided by different trades, or is work by the same trade in a different environment — Contractor shall implement the following three phases:

#### **14.2.1 Planning Phase**

Before beginning each work task: (a) review Contract Documents; (b) verify all materials and equipment have been tested, submitted, and approved; (c) examine the work area to confirm preliminary work is complete; (d) review quality control inspection and testing requirements; (e) document construction tolerances and workmanship standards; and (f) conduct a meeting attended by the Engineer, Quality Control Manager, superintendent, and the foreman responsible for the work task to instruct workers on the acceptable level of workmanship.

#### **14.2.2 Work Phase**

After completing the Planning Phase: (a) notify the Engineer at least one (1) week in advance of beginning the Work; (b) check that the Work is in full compliance with Contract Documents; (c) verify required control inspection and testing is performed; (d) verify established levels of workmanship meet acceptable standards; and (e) repeat the Work Phase for each new crew on-site or any time acceptable quality standards are not being met.

#### **14.2.3 Follow-Up Phase**

Perform daily checks to ensure compliance: (a) record observations in quality control documentation; (b) correct all defects prior to start of additional work tasks that may be affected by Defective Work — do not build upon or conceal Defective Work; and (c) conduct a review of the Work at least one (1) month prior to expiration of the correction period prescribed in Article 15, with the Owner.

### **14.3 Testing and Inspections**

Contractor shall perform all testing required by the Contract Documents, building codes, and regulatory agencies, including concrete cylinder tests, soil compaction tests, structural steel inspections, and any other tests specified. Testing shall be performed by independent testing agencies complying with ACIL standards approved by the City. Test reports shall be submitted within twenty-four (24) hours of completing the test. Failed tests shall be reported immediately to the Engineer. All testing required by Contract Documents shall be at Contractor's expense. Retesting due to failures shall also be at Contractor's expense.

### **14.4 Defective Work**

Work that does not conform to Contract Documents shall be considered Defective. Contractor shall immediately correct any Defective Work or notify the Engineer explaining why corrective action cannot be completed immediately and when it will be completed. No payment will be made for Defective Work; remove from the Application for Payment any Work paid for on a previous Application that is subsequently found to be Defective. Work connected or adjacent to Defective Work, or Work that would have to be removed to correct Defective Work, is also considered Defective. Contractor is responsible for all costs associated with replacing any acceptable Work that must be removed or might be damaged by corrective actions.

### **14.5 City Inspections**

The City and its representatives shall have access to the work at all times for inspection. Contractor shall provide safe access and shall not cover any work required to be inspected until inspected and approved. If the City requests inspection of work already covered, Contractor shall uncover it and

properly restore. If work is found to be Defective, costs shall be borne by Contractor. If work is found to be acceptable, the City shall pay for uncovering and restoration by Change Order.

#### **14.6 Material Certifications**

Contractor shall provide manufacturer's certifications for materials as required by specifications, including mill certifications for structural steel, manufacturer's data sheets, fire ratings and listings, energy efficiency ratings, and warranty documentation.

## **ARTICLE 15: WARRANTIES AND GUARANTEES**

---

### **15.1 General Warranty**

Contractor warrants that all work shall be: (a) free from defects in materials and workmanship; (b) in accordance with Contract Documents; (c) performed in a good and workmanlike manner; and (d) in compliance with all applicable codes and regulations.

#### **15.1.1 Warranty Exclusions**

Contractor's warranty does not apply to defects or damage caused by abuse, misuse, improper operation by the City, failure to perform routine maintenance, normal wear and tear, vandalism, acts of God, or work performed by others after Substantial Completion. This exclusion does not apply to defects resulting from Contractor's defective Work, improper installation, or failure to comply with the Contract Documents.

### **15.2 One-Year Correction Period**

Contractor shall correct any defects in materials or workmanship appearing within one (1) year from the date of Substantial Completion at no cost to the City. This warranty is in addition to any manufacturer's warranties. If work is corrected during the warranty period, the warranty for that portion of work shall be extended for one (1) year from the date of correction.

#### **15.2.1 Warranty Period for Post-Substantial Completion Work**

For punch list items, deferred work, or any Work completed after Substantial Completion, the one-year warranty period for that specific Work shall begin on the date the Work is completed and accepted by the City, not on the date of Substantial Completion.

### **15.3 Extended Warranties**

Certain systems and components require extended warranties as specified in Contract Documents. Contractor shall provide extended warranties as required by the specifications for the project scope.

### **15.4 Warranty Claims and Response Requirements**

The City shall notify Contractor in writing of observed defects during the warranty period. Upon receipt of warranty claim notification, Contractor shall:

- Respond within two (2) business days with a proposed plan and schedule for corrective action;
- Commence corrective Work within seven (7) calendar days; and
- Complete corrective Work within the timeframe directed by the City.

**Emergency Response:** For defects that create a safety hazard, risk of property damage, or interruption of essential services, Contractor shall respond within twenty-four (24) hours and commence corrective Work immediately.

#### **15.4.1 City's Right to Correct**

If Contractor fails to respond or to correct Defective Work within the times required under Section 15.4, the City may, after written notice to Contractor, perform or cause the corrective Work to be performed. Contractor shall reimburse the City for all reasonable costs incurred, including labor, materials, and administrative costs. The City may deduct such costs from retainage, from amounts otherwise due to Contractor, or recover such costs through the performance bond.

#### **15.5 Manufacturer's Warranties**

Contractor shall obtain and deliver to the City all manufacturer's warranties covering equipment, materials, and systems. Manufacturer's warranties shall be issued in the City's name and shall commence on the later of Substantial Completion, start-up, or acceptance of the applicable system or equipment, unless the Contract Documents require a different commencement date.

#### **15.6 Warranty Bond (If Required)**

If specified, Contractor shall provide a warranty bond guaranteeing obligations under the warranty provisions.

#### **15.7 Warranty Documentation Matrix**

Within fourteen (14) days of Substantial Completion, Contractor shall provide a warranty matrix identifying each warranted item or system, warranty duration, warranty start date, manufacturer name, installer name and contact information, a single designated warranty point of contact responsible for coordinating all warranty requests, and any required maintenance actions necessary to maintain warranty validity. This matrix shall be included in the Operations and Maintenance Manuals.

### **ARTICLE 16: PROJECT CLOSEOUT**

---

#### **16.1 Substantial Completion**

##### **16.1.1 Request for Substantial Completion**

When Contractor considers the work substantially complete, Contractor shall: (a) conduct internal inspections with Superintendent, Subcontractors, and Suppliers to create a deficiency list; (b) correct all identified deficiencies; and (c) submit written request for Substantial Completion inspection including a statement that work is substantially complete, a list of minor items remaining to be completed (preliminary punch list) with expected completion dates, and copies of required certifications and approvals.

##### **16.1.2 Substantial Completion Inspection**

Within ten (10) days of request, the City shall conduct inspection to determine if work is substantially complete. The City shall prepare a punch list of items requiring completion or correction.

##### **16.1.3 Certificate of Substantial Completion**

The Certificate of Substantial Completion shall establish: (a) the date of Substantial Completion governing commencement of warranty periods under Article 15 (except for Work completed after Substantial Completion as described in Section 15.2.1); (b) responsibilities of City and Contractor for security, maintenance, and utilities; (c) time for completing punch list items; and (d) commencement of warranty period. Contractor shall object to any items on the Certificate within ten (10) days of receipt.

## **16.2 Punch List Completion**

Contractor shall complete all punch list items within thirty (30) days of Substantial Completion or within the time specified in the Certificate of Substantial Completion. The City may withhold final payment until all punch list items are completed.

## **16.3 Final Completion Requirements**

Before final payment, Contractor shall provide all of the following:

### **16.3.1 Record Documents**

Complete set of as-built Record Drawings in hard copy and electronic formats (PDF and AutoCAD .dwg), clearly marked "RECORD DRAWINGS," showing: all changes made during construction; exact locations of all underground utilities and piping; actual dimensions and elevations; and equipment locations and model numbers. Also submit all monthly red-line drawings accumulated throughout construction.

### **16.3.2 Operations and Maintenance Manuals**

Complete O&M manuals including: (a) table of contents organized by specification section; (b) operating instructions for all equipment and systems; (c) maintenance procedures and schedules; (d) parts lists and supplier contact information; (e) a detailed listing of all subcontractors retained under each specification section, including their respective contact information and the length of warranty coverage for work performed, with warranty periods beginning on the date of Substantial Completion; (f) warranty information and warranty matrix per Section 15.7; (g) emergency procedures; (h) shop drawings and product data; and (i) test reports and certifications. Manuals shall be organized in three-ring binders with tabs and submitted in both hard copy (3 sets) and electronic formats, written in clear, concise language.

### **16.3.3 Training**

Contractor shall provide training for City personnel on operation and maintenance of all systems and equipment. Training shall include: minimum four (4) hours of hands-on training (additional training may be required depending on facility type); training during normal business hours; training for designated City and FAST personnel; and documentation of training provided.

### **16.3.4 Additional Closeout Documentation**

Contractor shall also submit:

- Equipment Installation Reports;
- All warranties, bonds, and service agreements executed per Article 15, identifying each warranted item, scope of warranty, date, duration, expiration date, procedures for failure, and specific instances that might invalidate the warranty;
- Certificates of Occupancy and all required permits;
- Consent of surety to final payment;
- Final lien waivers from all subcontractors and suppliers;
- Final DBE/SDBE utilization report;
- Final NC Sales Tax Affidavit;
- Final weekly certified payrolls (Davis-Bacon compliance);
- Affidavit that all payrolls, materials, and other indebtedness connected with the Work have been paid;
- Evidence of continuing insurance and bond coverage;

- Keys and keying schedule, access cards, fobs, and codes;
- All spare parts and maintenance materials as specified.

#### **16.4 Reinspection Fees**

The City may impose a set-off against the Application for Payment to compensate the City for additional site visits required if Contractor calls for a Substantial or Final Completion inspection before the work is ready.

#### **16.5 Final Inspection and Acceptance**

After completing all punch list items and submitting all closeout documentation, Contractor shall request final inspection in writing. The City shall conduct final inspection within ten (10) days of request. If work is acceptable, the City shall issue a Certificate of Final Completion. Acceptance of final payment shall constitute a waiver of all claims by Contractor except those previously made in writing and still unsettled.

### **ARTICLE 17: FEDERAL TRANSIT ADMINISTRATION (FTA) REQUIREMENTS**

---

**Applicability:** This Article applies because this Contract is funded in whole or in part with financial assistance from the Federal Transit Administration (FTA) under 49 U.S.C. Chapter 53. All requirements in this Article shall be flowed down to subcontracts at all tiers unless otherwise specified. The Federal funding source is FTA and the Federal funding amount is \$\_\_\_\_\_.

#### **17.1 Disclaimer — No Federal Government Obligation to Third Parties**

The Contractor and any subcontractors acknowledge and agree that, notwithstanding any concurrence by the Federal Government in or approval of the solicitation or award of this Contract, absent the express written consent by the Federal Government, the Federal Government is not a party to this Contract and shall not be subject to any obligations or liabilities to the Contractor, or any other party (whether or not a party to this Contract) pertaining to any matter resulting from this Contract. This clause shall be included in each subcontract and shall not be modified, except to identify the subcontractor who will be subject to its provisions.

#### **17.2 Program Fraud and False or Fraudulent Statements**

(31 U.S.C. §§ 3801 et seq.; 2 CFR § 200.113; 18 U.S.C. § 1001; 49 U.S.C. § 5307) (1) The Contractor acknowledges that the provisions of the Program Fraud Civil Remedies Act of 1986, as amended, 31 U.S.C. §§ 3801 et seq., and U.S. DOT regulations, "Program Fraud Civil Remedies," 49 C.F.R. Part 31, apply to its actions pertaining to this Project. Upon execution of this Contract, the Contractor certifies or affirms the truthfulness and accuracy of any statement it has made, it makes, it may make, or causes to be made, pertaining to this Contract or the FTA-assisted project. If the Contractor makes a false, fictitious, or fraudulent claim, statement, submission, or certification, the Federal Government reserves the right to impose the penalties of the Program Fraud Civil Remedies Act on the Contractor to the extent the Federal Government deems appropriate. (2) The Contractor also acknowledges that if it makes a false, fictitious, or fraudulent claim, statement, submission, or certification to the Federal Government, the Government reserves the right to impose the penalties of 18 U.S.C. § 1001 and 49 U.S.C. § 5307(n)(1) to the extent the Federal Government deems appropriate. (3) The Contractor agrees to include the above two clauses in each subcontract, modified only to identify the subcontractor.

#### **17.3 Federal Changes**

(2 CFR Part 200) Contractor shall at all times comply with all applicable Federal regulations, policies, procedures, and directives, including without limitation those listed directly or by reference in the Master Agreement between the City of Fayetteville / FAST and the Federal grantor agency (FTA), as they may be amended or promulgated from time to time during the term of this Contract. Contractor's failure to so comply shall constitute a material breach of this Contract.

#### **17.4 Access to Records and Reports**

(49 U.S.C. § 5325; 2 CFR § 200.336; 49 CFR § 633.17) The Contractor agrees to provide the City, FTA, the Comptroller General of the United States, and any of their authorized representatives access to any books, documents, papers, and records of the Contractor which are directly pertinent to this Contract for the purposes of making audits, examinations, excerpts, and transcriptions. Contractor also agrees, pursuant to 49 CFR § 633.17, to provide FTA or its authorized representatives including any PMO Contractor access to Contractor's records and construction sites pertaining to a major capital project receiving federal financial assistance through the programs described at 49 U.S.C. §§ 5307, 5309, or 5311. The Contractor agrees to maintain all books, records, accounts, and reports required under this Contract for a period of not less than three (3) years after the date of termination or expiration of this Contract, except in the event of litigation or settlement of claims arising from performance of this Contract, in which case Contractor agrees to maintain same until all litigation, appeals, claims, or exceptions have been disposed of. Reference 2 CFR § 200.334.

#### **17.5 Civil Rights and Non-Discrimination**

##### **17.5.1 General Nondiscrimination**

(42 U.S.C. § 2000d; 42 U.S.C. § 6102; 42 U.S.C. § 12132; 49 U.S.C. § 5332) In accordance with Title VI of the Civil Rights Act, as amended, section 303 of the Age Discrimination Act of 1975, section 202 of the Americans with Disabilities Act of 1990, and Federal transit law at 49 U.S.C. § 5332, the Contractor agrees that it will not discriminate against any employee or applicant for employment because of race, color, creed, national origin, sex, age, or disability. In addition, the Contractor agrees to comply with applicable Federal implementing regulations and other implementing requirements FTA may issue.

##### **17.5.2 Title VI of the Civil Rights Act**

(42 U.S.C. §§ 2000d et seq.; 49 C.F.R. Part 21) The Contractor agrees to comply with all provisions prohibiting discrimination on the basis of race, color, or national origin. The Contractor shall include Title VI assurances in every subcontract financed in whole or in part with Federal assistance. Contractor shall comply with implementing regulations of the applicable federal funding agency, including 49 C.F.R. Part 21 (Nondiscrimination in Federally-Assisted Programs of the Department of Transportation).

##### **17.5.3 Equal Employment Opportunity (EEO)**

(42 U.S.C. § 2000e; 49 U.S.C. § 5332) In accordance with Title VII of the Civil Rights Act, as amended, and Federal transit laws at 49 U.S.C. § 5332, the Contractor agrees to comply with all applicable equal employment opportunity requirements of U.S. Department of Labor regulations and any applicable Federal statutes, executive orders, regulations, and Federal policies that may affect construction activities undertaken in the course of the Project. The Contractor agrees to take affirmative action to ensure that applicants are employed and that employees are treated during employment without regard to their race, color, creed, national origin, sex, age, or disability. Note: References to Executive Order 11246 and Executive Order 11375 have been removed as these orders were rescinded by Executive Order 14173 on January 21, 2025, effective April 21, 2025.

#### **17.5.4 Age and Disability Non-Discrimination**

In accordance with section 4 of the Age Discrimination in Employment Act of 1967, as amended, 29 U.S.C. §§ 623, and Federal transit law at 49 U.S.C. § 5332, the Contractor agrees to refrain from discrimination against present and prospective employees for reason of age. In accordance with section 102 of the Americans with Disabilities Act, as amended, 42 U.S.C. § 12112, the Contractor agrees to comply with the requirements of U.S. Equal Employment Opportunity Commission regulations at 29 C.F.R. Part 1630, pertaining to employment of persons with disabilities.

#### **17.5.5 ADA Accessibility**

(42 U.S.C. § 12101 et seq.; 29 U.S.C. § 794; 49 U.S.C. § 5301(d)) The Contractor agrees to comply with all applicable requirements of the Americans with Disabilities Act of 1990, as amended; section 504 of the Rehabilitation Act of 1973, as amended; 49 U.S.C. § 5301(d); and any implementing Federal regulations. No individual with a disability shall, solely by reason of such disability, be excluded from participation in, be denied the benefits of, or be subjected to discrimination under any program or activity resulting from this Contract.

#### **17.5.6 Title IX — Non-Discrimination on Basis of Sex**

(20 U.S.C. §§ 1681 et seq.) The Contractor agrees to comply with all applicable requirements of Title IX of the Education Amendments of 1972, as amended, and with implementing Federal regulations that prohibit discrimination on the basis of sex.

#### **17.5.7 Environmental Justice**

(Executive Order No. 12898) The Contractor agrees to comply with the policies of Executive Order No. 12898, "Federal Actions to Address Environmental Justice in Minority Populations and Low-Income Populations," 42 U.S.C. § 4321 note.

#### **17.5.8 Access for Persons with Limited English Proficiency**

(Executive Order No. 13166) To the extent applicable, the Contractor agrees to comply with the policies of Executive Order No. 13166, "Improving Access to Services for Persons with Limited English Proficiency," 42 U.S.C. § 2000d-1 note.

#### **17.5.9 Flow-Down, Posting, and Compliance Verification**

Contractor shall: (a) include the requirements of this Section 17.5 in every subcontract and purchase order; (b) post in conspicuous places available to employees and applicants for employment notices setting forth applicable non-discrimination requirements; (c) permit access to books, records, accounts, and work sites for investigation to ascertain compliance; and (d) maintain records demonstrating nondiscrimination compliance for three (3) years following project completion.

#### **17.6 Disadvantaged Business Enterprise (DBE)**

(49 CFR Part 26, as amended by Interim Final Rule effective October 3, 2025) As of October 3, 2025, the U.S. Department of Transportation issued an Interim Final Rule (Docket No. DOT-OST-2025-0897) that substantially modified the DBE program under 49 CFR Part 26. The rule eliminates race- and gender-based presumptions of social and economic disadvantage. See Article 7 for the full DBE/SDBE requirements. Contractor also agrees to include these requirements in each subcontract financed in whole or in part with Federal assistance, modified only if necessary to identify the affected parties.

#### **17.7 Buy America Requirements**

**Authority:** 49 U.S.C. § 5323(j); 49 CFR Part 661. **Applicability:** Contracts over \$150,000 involving purchase of iron, steel, and manufactured products used in FTA-funded projects.

The Contractor shall comply with 49 U.S.C. § 5323(j) and 49 CFR Part 661, which provide that federal funds may not be obligated unless all steel, iron, and manufactured products used in FTA-funded projects are produced in the United States, unless a waiver has been granted by FTA or the product is subject to a general waiver. Specifically:

- **Steel and Iron:** All manufacturing processes, from initial melting through final coating, must occur in the United States. This is a 100% domestic requirement — no partial compliance permitted on steel and iron.
- **Manufactured Products:** Must be manufactured in the United States and the cost of U.S. components must exceed 55% of the total component cost of the manufactured product.
- **Certification Required:** Contractor must submit a signed Buy America Certification (Attachment O to the ITB) with its bid and maintain documentation demonstrating compliance throughout the Contract.
- **Flow-Down:** Contractor shall include Buy America requirements in all subcontracts at all tiers and obtain Buy America certifications from all subcontractors and material suppliers.
- **Waivers:** Waiver requests must be submitted through the City to FTA prior to procurement of any non-domestic items. Waivers may be granted if: (a) applying the requirement would be inconsistent with the public interest; (b) the materials are not produced in the U.S. in sufficient quantities or of satisfactory quality; or (c) use of domestic material will increase the cost of the overall project contract by more than 25%.

### **17.8 Davis-Bacon Act Prevailing Wages**

(40 U.S.C. § 3141 et seq.; 29 CFR Part 5) All laborers and mechanics employed under this Contract and all subcontracts shall be paid wages at rates not less than those established in the wage determination included in the Contract Documents (Attachment J — Davis-Bacon Rate Forms). Contractor shall: (a) post the applicable wage determination at the work site in a prominent, accessible location where it can easily be seen by workers; (b) pay all laborers and mechanics at least weekly; (c) submit weekly Certified Payrolls to the City on U.S. Department of Labor Form WH-347 (or equivalent); (d) maintain payroll records for three (3) years after project completion; (e) include Davis-Bacon requirements in all subcontracts. Failure to comply may result in withholding of payments, termination of Contract, liability for back wages, and debarment from future federal contracts.

### **17.9 Contract Work Hours and Safety Standards Act**

(40 U.S.C. §§ 3701 et seq.; 29 CFR Part 5) No laborer or mechanic shall be required or permitted to work more than forty (40) hours in any workweek unless paid overtime at a rate not less than one and one-half times the basic rate of pay for all hours worked in excess of forty hours. Violation may result in liability for unpaid wages and liquidated damages of \$10 per worker per day of violation. These requirements shall be included in all subcontracts.

### **17.10 Copeland Anti-Kickback Act**

(40 U.S.C. § 3145) Contractor shall comply with the Copeland "Anti-Kickback" Act, which prohibits inducing any employee to give up any part of compensation to which entitled and receiving kickbacks from employees.

### **17.11 Lobbying Restrictions**

(31 U.S.C. § 1352; 2 CFR Part 200, Appendix II; 49 CFR Part 20) For contracts and subcontracts of \$100,000 or more, Contractor certifies that no Federal appropriated funds have been paid or will be paid to any person for influencing or attempting to influence an officer or employee of any agency, a

Member of Congress, or an employee of a Member of Congress in connection with the award of this Contract. If any non-Federal funds have been paid for such purposes, Contractor shall complete and submit Standard Form-LLL, "Disclosure Form to Report Lobbying." This certification shall be included in all sub-awards at all tiers (see Attachment L — Certification and Restrictions on Lobbying).

### **17.12 Debarment and Suspension**

(2 CFR Parts 180 and 3000) The Contractor, by submitting a proposal, certifies that neither it nor its principals are presently debarred, suspended, proposed for debarment, declared ineligible, or voluntarily excluded from covered transactions by any Federal department or agency; and have not within a three-year period preceding this proposal been convicted of or had a civil judgment rendered against them for fraud or criminal offense in connection with a public transaction.

### **17.13 Drug-Free Workplace**

(2 CFR Part 182; 41 U.S.C. §§ 8101 et seq.) Contractor shall adhere to Federal Drug-Free Workplace requirements, publish a workplace statement, establish drug-free awareness programs, and take action concerning employees convicted of violating drug statutes in the workplace. Failure to comply shall constitute a material breach of this Contract.

### **17.14 FTA Drug and Alcohol Testing for Safety-Sensitive Functions**

(49 U.S.C. § 5331; 49 CFR Parts 655 and 40) Contractor agrees to establish and implement a drug and alcohol testing program that complies with 49 CFR Parts 655 and 40, submit required Management Information System (MIS) reports, and certify compliance with FTA drug and alcohol testing requirements. Safety-sensitive functions include: operating a revenue service vehicle; operating a non-revenue service vehicle requiring a CDL; controlling dispatch or movement of a revenue service vehicle; maintaining revenue service vehicles or equipment; and carrying a firearm for security purposes. This clause shall flow down to subcontracts at all tiers involving performance of a safety-sensitive function.

### **17.15 Charter Service Operations**

(49 U.S.C. §§ 5323(d), (g), (r); 49 CFR Part 604) Contractor agrees that recipients and subrecipients of FTA assistance are prohibited from providing charter service using federally-funded equipment or facilities if there is at least one private charter operator willing and able to provide the service, except under limited circumstances specified in 49 CFR Part 604. This clause shall be included in each subcontract that may involve operating public transit services.

### **17.16 School Bus Operations**

(49 U.S.C. § 5323(f); 49 CFR Part 605) Contractor agrees that recipients and subrecipients may not engage in school bus operations using federally-funded equipment or facilities in competition with private school bus operators unless qualified under specified exemptions. This clause shall flow down to all subcontracts involving vehicles or transit operations.

### **17.17 Transit Employee Protective Arrangements**

(49 U.S.C. § 5333(b); 29 CFR Part 215) For contracts involving transit operations previously performed by public employees, Contractor agrees to: preserve rights and benefits under existing collective bargaining agreements; continue collective bargaining rights; protect employees against worsening of employment positions; assure priority of re-employment of terminated or laid-off employees; and provide training programs and up to six (6) years of severance pay. Operations must be certified by the U.S. Secretary of Labor as fair and equitable.

### **17.18 Fly America Requirements**

(49 U.S.C. § 40118; 41 CFR Part 301-10) Contractor agrees to comply with the Fly America Act, which provides that FTA assistance may not fund transportation of persons or property by any air carrier other than a U.S. flag air carrier unless no U.S. flag carrier provides service on that leg, use of a U.S. carrier would extend travel time by 24 hours or more, or use is a matter of necessity.

### **17.19 Cargo Preference — Use of U.S.-Flag Vessels**

(46 U.S.C. § 55305; 46 CFR Part 381) Contractor agrees to use privately owned U.S.-flag commercial vessels to ship at least 50% of gross tonnage when shipping equipment, materials, or commodities pursuant to this Contract, to the extent such vessels are available at fair and reasonable rates. Contractor shall furnish a copy of the rated on-board bill of lading to both the City and the Division of National Cargo, Maritime Administration, Washington, DC 20590 within 20 days following the date of loading.

### **17.20 Privacy Act**

(5 U.S.C. § 552a) The Contractor agrees to comply with the information restrictions and other applicable requirements of the Privacy Act of 1974, and to obtain the express consent of the Federal Government before the Contractor or its employees operate a system of records on behalf of the Federal Government. These requirements shall be included in each subcontract that involves administering any system of records on behalf of the Federal Government.

### **17.21 Trafficking in Persons**

(2 CFR § 175.15; 22 U.S.C. § 7104(g)) The Contractor certifies that neither it nor its principals or subcontractors: (a) engages in severe forms of trafficking in persons; (b) procures commercial sex acts; or (c) uses forced labor in performance of the contract. Prohibited activities include: destroying, concealing, confiscating, or denying access to identity or immigration documents; using misleading or fraudulent recruitment practices; charging recruitment fees; and failing to provide return transportation costs upon end of employment. Violation may result in termination, debarment, or suspension from future federal contracts.

### **17.22 Seismic Safety**

(42 U.S.C. § 7701 et seq.; Executive Order 12699) To the extent applicable, Contractor agrees to comply with the Earthquake Hazards Reduction Act of 1977 and Executive Order 12699, Seismic Safety of Federal and Federally Assisted or Regulated New Building Construction, which require implementation of appropriate seismic design and construction standards for new building construction and major rehabilitation.

### **17.23 Energy Conservation**

(42 U.S.C. §§ 6321 et seq.; 2 CFR Part 200) The Contractor agrees to comply with mandatory standards and policies relating to energy efficiency which are contained in the state energy conservation plan issued in compliance with the Energy Policy and Conservation Act.

### **17.24 Clean Air Act**

(42 U.S.C. §§ 7401 et seq.; 2 CFR § 200.328) The Contractor agrees to comply with all applicable standards, orders, or regulations issued pursuant to the Clean Air Act, as amended. The Contractor agrees to report each violation to the City, which will in turn report each violation to FTA and the appropriate EPA Regional Office. These requirements shall be included in each subcontract exceeding \$100,000.

### **17.25 Clean Water Act**

(33 U.S.C. §§ 1251 et seq.; 2 CFR § 200.328) The Contractor agrees to comply with all applicable standards, orders, or regulations issued pursuant to the Federal Water Pollution Control Act, as amended. The Contractor agrees to report each violation to the City for reporting to FTA and the appropriate EPA Regional Office. These requirements shall be included in each subcontract exceeding \$100,000.

### **17.26 Historic Preservation**

(54 U.S.C. § 306108; 36 CFR Part 800) For projects that may affect historic properties, Contractor agrees to: take into account the effects of the undertaking on any historic property; provide the City with information needed for Section 106 consultation; cease work if unanticipated historic properties or artifacts are discovered; notify the City immediately of any discoveries; and comply with all conditions in any Programmatic Agreement or Memorandum of Agreement.

### **17.27 FTA Notification**

Contractor shall notify FTA of any delays, changed conditions, or problems of any magnitude that may affect completion of the work, participate in project meetings as required, and provide progress reports as specified in this Contract.

### **17.28 Contractor Assurance**

The Contractor, by submitting a proposal, shall adhere to all applicable Federal provisions listed in this Article. Failure to comply with Federal provisions shall be considered a material breach of contract. Contractor is responsible for ensuring its compliance with all applicable Federal requirements, and for ensuring that subcontractors, at as many tiers of the Project as required, perform in accordance with all applicable Federal requirements. Upon request, Contractor shall provide evidence of steps taken to ensure its compliance and subcontractor compliance at all tiers.

## **ARTICLE 18: ENVIRONMENTAL COMPLIANCE AND EROSION CONTROL**

---

### **18.1 General Environmental Protection**

Contractor shall conduct operations in a manner that minimizes environmental impacts and complies with all environmental laws and regulations, including the Clean Water Act, Clean Air Act, Resource Conservation and Recovery Act, North Carolina environmental regulations, and local ordinances.

### **18.2 Erosion and Sediment Control**

If the project disturbs one acre or more, Contractor shall: (a) obtain coverage under NC's NPDES General Permit (NCG01); (b) prepare and implement an Erosion and Sediment Control Plan in accordance with N.C. Gen. Stat. § 113A-50 et seq.; (c) install and maintain erosion control measures including silt fencing, sediment basins, inlet protection, and temporary stabilization; (d) conduct inspections at least every seven (7) days and within 24 hours of storm events; and (e) maintain records available for inspection. Contractor shall implement best management practices to prevent pollution of stormwater including proper storage of materials, containment of concrete washout, dust control, prevention of tracking sediment onto public streets, and protection of storm drain inlets.

### **18.3 Pollution Control**

Contractor shall prevent contamination of soil, water, or atmosphere by the discharge of noxious substances. Chemicals shall be contained in protective areas and not dumped on soil. If contamination of soil occurs, Contractor shall excavate and dispose of contaminated material off-site at a licensed facility and provide documentation of the nature, strength, method of disposal, and location of the disposal site. Groundwater or run-off water which has come into contact with noxious chemicals is considered contaminated and shall not enter streams or watercourses.

#### **18.4 Hazardous Materials Management**

Contractor shall: (a) store all hazardous materials in approved containers; (b) maintain Safety Data Sheets (SDS) on site; (c) implement spill prevention measures; (d) have spill response equipment readily available; and (e) immediately report spills to the City and appropriate agencies. Solid waste shall go to licensed landfills; hazardous waste through licensed hazardous waste haulers. If work involves structures built before 1978 or that may contain asbestos, Contractor shall comply with OSHA asbestos standards (29 C.F.R. § 1926.1101) and EPA Lead Renovation, Repair and Painting Rule (40 C.F.R. Part 745).

#### **18.5 Wetlands and Protected Areas**

Contractor shall not disturb wetlands, streams, or other protected environmental areas without proper permits from the U.S. Army Corps of Engineers, NC Department of Environmental Quality, and other agencies having jurisdiction.

#### **18.6 Tree Protection**

Contractor shall protect trees designated for preservation by installing tree protection fencing at the drip line and prohibiting storage, traffic, or construction activities within protected areas. Contractor shall be liable for damage to protected trees at the rate specified in Contract Documents or \$1,000 per caliper inch, whichever is greater.

### **ARTICLE 19: SAFETY REQUIREMENTS**

---

#### **19.1 Safety Program**

Contractor shall establish and maintain a project-specific Site Safety Program complying with OSHA regulations (29 C.F.R. Part 1926) and NC Department of Labor requirements. Corporate safety handbooks or programs are not acceptable substitutes for a project-specific Site Safety Program. Submit the Site Safety Program within ten (10) days of Notice to Proceed.

#### **19.2 OSHA Compliance**

Contractor shall comply with all applicable OSHA standards, including but not limited to: fall protection (29 C.F.R. § 1926.501); scaffolding (29 C.F.R. § 1926.451); excavation and trenching (29 C.F.R. § 1926.651); electrical safety (29 C.F.R. § 1926.400); personal protective equipment (29 C.F.R. § 1926.95); and hazard communication (29 C.F.R. § 1926.59). Contractor shall designate competent persons as required by OSHA for excavation and trenching operations, scaffolding erection and inspection, fall protection systems, and other operations requiring competent person oversight.

#### **19.3 Safety Meetings and Training**

Contractor shall: (a) conduct daily toolbox safety talks; (b) hold weekly safety meetings; (c) provide OSHA 10-hour or 30-hour training for workers as appropriate; (d) train workers on hazard communication (HazCom); and (e) maintain training records.

## **19.4 Accident Reporting**

Contractor shall immediately report to the City: all fatalities and serious injuries; incidents requiring medical treatment beyond first aid; near-miss incidents; property damage incidents exceeding \$1,000; and spills or environmental releases. Contractor shall submit written accident reports within 24 hours using forms provided by the City and provide two copies of all accident reports, including insurance company reports, to the Engineer as Record Data.

## **19.5 Right to Stop Work**

The City reserves the right to stop work if Contractor's operations create imminent danger or serious safety violations. Contractor shall bear all costs associated with work stoppage due to safety violations. If the City or Engineer stops prosecution of work at any time because of life safety issues, such stoppage shall not relieve Contractor of its safety responsibilities under this Article.

# **ARTICLE 20: DISPUTES, CLAIMS, AND REMEDIES**

---

## **20.1 Claims Procedure**

### **20.1.1 Notice of Claim**

Any claim by Contractor for adjustment of Contract Sum or Contract Time must be submitted in writing to the City within ten (10) calendar days after occurrence of the event giving rise to the claim or within ten (10) days after Contractor knew or should have known of the facts giving rise to the claim.

### **20.1.2 Claim Documentation**

Each claim shall include: (a) detailed factual statement of claim; (b) specific Contract provisions supporting claim; (c) supporting documentation including schedules, cost records, correspondence; (d) amount claimed if monetary; (e) time extension requested if applicable; and (f) relief requested.

### **20.1.3 City Review**

The City shall review claims and respond in writing within thirty (30) days. Disputes arising in the performance of this Contract which are not resolved by agreement of the parties shall be decided in writing by the authorized representative of the City of Fayetteville's Director of Legal, Risk, and Procurement Services. This decision shall be final and conclusive unless within ten (10) days from the date of receipt of its copy, the Contractor files a written appeal.

## **20.2 Continuing Performance During Disputes**

Contractor shall continue to perform work diligently during pendency of any dispute or claim. Failure to continue performance may constitute material breach and grounds for termination. Unless otherwise directed by the City, Contractor shall continue performance under this Contract while matters in dispute are being resolved.

## **20.3 Mediation**

If the parties cannot resolve a dispute through negotiation, either party may request non-binding mediation pursuant to the Rules Implementing Mediated Settlement Conferences for Construction Disputes under North Carolina law. The parties shall share mediation costs equally. Mediation shall be conducted in Cumberland County, North Carolina. A protester must exhaust all administrative remedies with the City before pursuing a protest with the Federal grantor agency.

## **20.4 FTA Protest Escalation**

Reviews of protests by FTA as the Federal grantor agency are limited to: (1) violations of federal law or regulations and the standard of this section; and (2) violations of the City's protest procedures for failure to review a complaint or protest. Protests received by FTA other than those specified above will be referred to the City. Violations of state or local law will be under the jurisdiction of state or local authorities.

## **20.5 Litigation**

If mediation is unsuccessful or either party declines mediation, disputes may be resolved through litigation in accordance with Article 25 (Governing Law and Venue).

## **20.6 No Waiver of Sovereign Immunity**

Nothing in this Contract shall be construed as a waiver of the City's governmental immunity under North Carolina law.

## **20.7 Attorney's Fees**

If either party brings legal action to enforce this Contract, the prevailing party shall be entitled to recover reasonable attorney's fees and costs.

# **ARTICLE 21: SUSPENSION OF WORK**

---

## **21.1 City's Right to Suspend**

The City may, at any time and for any reason, suspend all or any portion of the work by giving written notice to Contractor. Upon receipt of notice, Contractor shall: (a) immediately suspend work as directed; (b) protect and secure work in place; (c) provide security as necessary; and (d) take reasonable measures to minimize costs.

## **21.2 Compensation for Suspension**

If suspension exceeds thirty (30) consecutive days and is not due to Contractor's fault, Contractor may be entitled to adjustment for: (a) actual costs of demobilization and remobilization; (b) actual costs of protecting and securing work; (c) actual extended general conditions costs; and (d) extension of Contract Time. Contractor shall not be entitled to anticipated profit on work not performed during suspension.

## **21.3 Resumption of Work**

The City shall provide written notice to resume work. Contractor shall resume work within seven (7) days of notice unless a different time is specified.

# **ARTICLE 22: CITY PAYMENT OBLIGATIONS**

---

City does hereby covenant and agree with Contractor that it will pay to Contractor, when due and payable under the terms of said Specifications and said Award, the above-mentioned sum, and that it will faithfully comply with and perform each and every obligation imposed upon it by said Specifications and the terms of said Award.

# **ARTICLE 23: TERMINATION PROVISIONS**

---

## **23.1 Termination for Convenience of the City**

### **23.1.1 City's Right to Terminate**

The City may terminate this Contract, in whole or in part, for its convenience whenever the City determines that such termination is in the City's best interest. The City shall provide written notice of termination to Contractor specifying the extent of termination and the effective date, which shall be not less than ten (10) calendar days from the date of the notice.

**FTA Acknowledgment:** Notwithstanding any concurrence by the Federal Government in or approval of the solicitation or award of this Contract, absent the express written consent by the Federal Government, the Federal Government is not a party to this Contract, shall not be subject to any obligations or liabilities to the Contractor or any other party pertaining to any matter resulting from this Contract, and shall not be responsible for any costs of termination.

### **23.1.2 Contractor's Obligations Upon Notice**

Upon receipt of a notice of termination, and except as otherwise directed by the City, Contractor shall immediately proceed with the following: (a) stop work as specified in the notice on the date and to the extent specified; (b) terminate all subcontracts and orders to the extent they relate to the terminated work; (c) take all necessary action to protect and preserve property in Contractor's possession in which the City has or may acquire an interest; (d) transfer title and deliver to the City, in the manner directed, completed supplies and work in process, and parts, materials, tools, plans, drawings, information, and contract rights acquired or produced for the terminated work; (e) complete performance of work not terminated; (f) take protective action for City property; and (g) submit to the City, within sixty (60) calendar days from the effective date of termination, a properly supported termination settlement proposal.

### **23.1.3 Basis for Settlement**

Upon termination for convenience, Contractor shall be entitled to receive payment for: (a) completed work accepted by the City prior to the effective date of termination; (b) work in progress to the extent it represents value to the City; (c) materials and equipment purchased or irrevocably committed for purchase for use in the work (title passes to the City upon payment); (d) actual reasonable costs of settlement including accounting, legal, and clerical expenses; (e) demobilization costs actually incurred; (f) costs of breaking down and removing temporary facilities; and (g) a reasonable profit on the cost of work performed, excluding profit on settlement expenses and on materials returned to suppliers.

### **23.1.4 Excluded Costs**

The following costs shall NOT be allowable in the termination settlement: (a) anticipated profit on unperformed work; (b) costs that would have been incurred regardless of termination; (c) claims for damages, including loss of anticipated profits or revenue on work not performed; (d) costs not properly allocable to the terminated work; (e) costs for which Contractor has been or will be reimbursed under any other contract; and (f) excessive or unreasonable costs as determined by the City. In no event shall the total amount paid exceed the Contract Sum less payments already made.

### **23.1.5 Settlement Proposal Requirements**

Contractor's termination settlement proposal shall include: a detailed itemization of all claims; complete supporting documentation (paid invoices, certified payroll records, subcontractor termination settlement agreements, general ledger entries); a schedule of values showing percentage of completion at time of termination; an inventory of materials purchased; a list of all outstanding subcontracts and purchase orders with termination proposals; and certification by Contractor's authorized representative that the claim is made in good faith, supporting data is accurate and complete, and the amount claimed is just and proper.

### **23.1.6 City's Right to Audit**

The City shall have the right to audit and examine all books, records, and supporting documents relevant to the termination settlement proposal. Contractor shall preserve all such records for three (3) years after final settlement.

#### **23.1.7 Assignment of Subcontracts**

The City may require Contractor to assign to the City all or any part of Contractor's right, title, and interest under any or all subcontracts and purchase orders terminated as a result of the termination of this Contract.

#### **23.1.8 Continuing Obligations**

Termination of this Contract, either in whole or in part, shall not relieve Contractor of obligations for work not terminated, including warranty obligations under Article 15, indemnification obligations under Article 2.3, insurance obligations under Article 4 for work performed, and compliance with federal and state nondiscrimination requirements.

#### **23.1.9 Partial Termination**

If only part of the work is terminated, Contractor shall file a proposal for an equitable adjustment of the price for the continued portion of the Contract. The City shall make an equitable adjustment for any increase or decrease in cost or time required for performance of the remainder of the Contract.

### **23.2 Termination for Cause (Default)**

#### **23.2.1 Grounds for Termination**

The City may, subject to the provisions of Section 23.2.2, terminate this Contract in whole or in part if Contractor: (a) fails to perform the work within the time specified; (b) fails to make progress so as to endanger performance of this Contract in accordance with its terms; (c) fails to comply with any material term or condition of this Contract, including obligations regarding insurance, indemnification, bonds, compliance with laws, FTA requirements, Davis-Bacon, or quality of workmanship; or (d) anticipatorily repudiates its obligations under this Contract.

#### **23.2.2 Notice and Opportunity to Cure**

Before terminating this Contract for cause, the City shall provide written notice to Contractor specifying: (a) the nature and details of the default; (b) the corrective action required; and (c) the time period within which Contractor must cure the default. Contractor shall have ten (10) calendar days from receipt of such notice to cure the default or, if the default cannot reasonably be cured within ten (10) days, to commence cure and submit a written cure plan demonstrating how Contractor will diligently pursue cure to completion within a reasonable time. The City may approve an extended cure period not to exceed thirty (30) additional days.

#### **23.2.3 Termination After Failure to Cure**

If Contractor fails to cure the default within the specified time period or fails to diligently pursue an approved cure plan, the City may terminate this Contract by providing written notice of termination to Contractor. The termination shall be effective as specified in the notice, but no earlier than ten (10) calendar days after Contractor's receipt of the notice.

#### **23.2.4 Contractor's Obligations Upon Termination for Cause**

Upon receipt of a notice of termination for cause, Contractor shall: (a) immediately stop work on the date and to the extent specified; (b) place no further orders or subcontracts for materials or services related to the terminated work; (c) terminate all orders and subcontracts relating to the terminated work; (d) transfer title and deliver to the City all fabricated or unfabricated parts, work in process, completed work, supplies, equipment, construction documents, shop drawings, submittals, as-built drawings, O&M manuals, warranties, and other project documentation; (e) secure the construction

site and protect City property; (f) cooperate with and provide information to any replacement contractor; and (g) remove Contractor's tools, equipment, machinery, and surplus materials as directed.

#### **23.2.5 City's Rights to Complete the Work**

After termination for cause, the City may: (a) take over the construction work and prosecute the same to completion by contract or otherwise; (b) complete the work by whatever method the City deems expedient; (c) withhold payments to Contractor for set-off or partial payment of amounts owed; and (d) take possession of and utilize, in completing the work, any materials, equipment, tools, and facilities belonging to Contractor that are on the project site.

#### **23.2.6 Excess Reprourement Costs and Liability**

If the City terminates this Contract for cause, Contractor shall be liable to the City for excess costs incurred in completing the construction work, including: (a) costs of completing the work, whether by replacement contractors, City forces, or any combination; (b) the difference between the total contract amount and the total amount actually paid by the City to complete the work; (c) additional administrative, procurement, construction management, and inspection costs; (d) costs of project delays; (e) costs to correct defective work; (f) reasonable attorneys' fees and costs; and (g) any other actual damages directly resulting from Contractor's default.

#### **23.2.7 Payment After Termination for Cause**

After termination for cause, the City shall pay Contractor for: completed work accepted by the City prior to the effective date of termination, and reasonable costs incurred for mobilization and performing the terminated work that are properly allocable, adequately documented, and approved by the City. Contractor shall not be paid for: work not accepted by the City; defective or non-conforming work; costs incurred due to Contractor's fault or negligence; anticipated profit on unperformed work; or consequential damages.

#### **23.2.8 Contractor's Right to Dispute Termination**

If Contractor disputes the termination for cause, Contractor must, within thirty (30) calendar days of receiving the notice of termination, provide written notice to the City of such dispute specifying in detail the basis for the dispute. Failure to timely dispute the termination shall constitute Contractor's acceptance of the termination for cause and waiver of any right to contest it.

#### **23.2.9 Conversion to Termination for Convenience**

If, after termination for cause, it is determined through agreement or final court judgment that Contractor was not in default, the default was excusable, or the City wrongfully terminated the Contract, then the termination shall be deemed to have been a termination for convenience under Section 23.1 from the effective date. Contractor's sole remedy shall be payment in accordance with Section 23.1; Contractor shall not be entitled to recover anticipated profit on unperformed work, consequential damages, or any damages beyond those provided in Section 23.1.

#### **23.2.10 Cumulative Remedies**

The rights and remedies of the City provided in this Section 23.2 are not exclusive and are in addition to any other rights and remedies provided by law, equity, or under this Contract. Except as expressly provided regarding excess reprourement costs, neither party shall be liable to the other for consequential, incidental, indirect, or special damages arising out of termination for cause, including lost profits, lost business opportunities, or damage to reputation.

## **ARTICLE 24: ASSIGNMENT**

---

It is the intent of this Agreement to secure the personal services of Contractor and failure of Contractor for any reason to make the personal services available to the City of Fayetteville for the purposes described in this Agreement shall be cause for termination. Contractor shall not assign this Agreement without prior written consent of the City of Fayetteville. Contractor shall not assign any portion of the work to a subcontractor without complying with the subcontracting notice and approval requirements of this Contract. See Section 2.4 regarding contingent assignment of subcontracts.

## **ARTICLE 25: GOVERNING LAW AND VENUE**

---

### **25.1 Governing Law**

The validity, interpretation, and execution of this Agreement and the performance of and rights accruing under this Agreement are all to be governed by the laws of North Carolina. When this Contract is funded in whole or in part with federal funds, federal requirements take precedence over state and local requirements to the extent of any conflict.

### **25.2 Venue and Forum Selection**

If litigation proceeds in North Carolina state courts, the appropriate venue shall be Cumberland County (Fourteenth Judicial District of North Carolina). If litigation proceeds in federal court, the appropriate venue shall be the United States District Court for the Eastern District of North Carolina.

## **ARTICLE 26: COMPLIANCE WITH LAWS**

---

Contractor agrees to comply with all applicable statutes, ordinances, and regulations of the United States, the State of North Carolina, the City of Fayetteville, and units of local government. When this Contract is funded in whole or in part with federal funds, federal requirements take precedence over state and local requirements to the extent of any conflict, and Contractor shall include applicable federal requirements in all subcontracts.

## **ARTICLE 27: REGULATORY CERTIFICATIONS**

---

### **27.1 E-Verify**

Contractor acknowledges that E-Verify is the federal program operated by the US Department of Homeland Security and other federal agencies used to verify the work authorization of newly hired employees pursuant to federal law and in accordance with Article 2, Chapter 64 of the North Carolina General Statutes. Contractor pledges, attests, and warrants through execution of this Agreement that Contractor and all subcontractors currently employed or subsequently hired shall comply with all E-Verify requirements under NCGS § 64-26(a). All employers must be in compliance with E-Verify requirements to enter into contracts with the City of Fayetteville / FAST. Failure to comply shall be considered a breach of this Agreement.

### **27.2 Iran and Israel Divestment Certification**

Contractor certifies that: (i) it is not identified on the Final Divestment List or any other list of prohibited investments created by the NC State Treasurer pursuant to N.C.G.S. § 147-86.58; (ii) it has not been designated by the NC State Treasurer pursuant to N.C.G.S. § 147-86.81 as a company engaged in the boycott of Israel; and (iii) it will not take any action causing it to appear on the Treasurer's Final Divestment Lists during the term of this Agreement. Contractor further agrees

to reimburse the City for any and all damages, costs and attorneys' fees incurred by the City if this Agreement is voided due to Contractor appearing on the Treasurer's Final Divestment Lists.

### **27.3 Non-Collusion Certification**

The undersigned certifies that: (i) the prices in this proposal were arrived at independently without collusion, consultation, communication, or agreement with any other proposer or competitor; (ii) prices have not been knowingly disclosed to any other proposer prior to opening; and (iii) no attempt has been made to induce any other person to submit or not submit a bid on any portion of the project work.

### **27.4 Conflict of Interest Certification**

Contractor certifies that performance of the work will not create any conflicts of interest under federal, state, or local law. Contractor agrees to disclose immediately any circumstances that could give rise to a conflict of interest during performance of this Contract.

## **ARTICLE 28: ENGINEER'S ROLE AND AUTHORITY**

---

### **28.1 Engineer as City's Representative**

The City may designate a licensed Engineer or Engineering firm to serve as its representative for contract administration during construction. Where designated, the Engineer shall be the first point of contact for all matters concerning contract administration, clarification and interpretation of Contract Documents, contract modifications, observation of work and testing, and claims. Engineer will coordinate correspondence concerning these matters and will normally communicate only with the Contractor; any required communication with Subcontractors or Suppliers will be with the direct involvement of the Contractor.

### **28.2 Engineer's Authority**

Where an Engineer has been designated, the Engineer is authorized to: interpret Contract Documents; observe work and determine compliance; recommend payment of Applications for Payment; issue Field Orders, Change Orders, and Contract Amendments; certify Substantial and Final Completion; and maintain Decision and Action Item Registers. The Engineer's decisions on matters within its authority shall be binding unless appealed under Article 20.

### **28.3 Limitation of Authority**

The Engineer is not authorized to: alter the requirements of the Contract Documents; accept or reject any portion of the work on the City's behalf without City concurrence for significant matters; perform any of the duties of the Contractor; direct or stop the Work except for life-safety issues or per City authorization; accept or approve substitutions without City concurrence; or authorize changes in Contract Price or Contract Times without an executed Change Order.

### **28.4 Engineer's Review Limitations**

The Engineer's recommendation of payment does not represent that inspections were exhaustive or extended to every aspect of the work, nor does it relieve Contractor of responsibility for errors, omissions, means, methods, or safety. The Engineer's review of submittals is for general conformance with design concept only and does not relieve Contractor of responsibility for compliance with Contract Documents.

## **ARTICLE 29: PRE-CONSTRUCTION CONFERENCE AND PROJECT COORDINATION**

---

### **29.1 Pre-Construction Conference**

A Pre-Construction Conference shall be held after the Notice of Award is issued and not later than fifteen (15) days after the Notice to Proceed is issued, at a location designated by the Engineer. No construction shall commence until the Pre-Construction Conference has been held. The following shall attend: Owner, Contractor's project manager and superintendent, representatives of utility companies, and representatives of major Subcontractors and Suppliers. Contractor shall provide and be prepared to discuss:

- Preliminary Construction Progress Schedule (CPM);
- Schedule of Documents listing all required submittals with anticipated submission dates;
- Schedule of Values and anticipated schedule of payments;
- List of Subcontractors and Suppliers;
- Organizational chart as it relates to this Project;
- Letter indicating agents of authority for the Contractor and the limit of that authority with respect to execution of legal documents, contract modifications, and payment requests;
- Traffic Control Plan (within 14 days of award per Section 11.7);
- Project-specific Site Safety Program.

### **29.2 Progress Meetings**

Contractor shall attend monthly progress meetings with the Engineer and City. Contractor's superintendent and key personnel shall attend. Contractor shall notify the Engineer of specific items to be discussed at least one (1) week prior to the meeting. The Engineer will prepare meeting minutes; Contractor shall review and notify the Engineer of any discrepancies within ten (10) days. Corrections will be reflected in the record of the following meeting.

### **29.3 Weekly Coordination Meetings**

Contractor shall meet with the Engineer or City's on-site representative on a weekly basis to discuss work planned for the following week, coordination issues, testing required, and other matters. Records of these meetings are not required unless directed by the Engineer.

### **29.4 Requests for Information**

Contractor shall submit Requests for Information (RFIs) to the Engineer on forms provided by the Engineer. Each RFI shall address a single item and include adequate information to permit a response without further clarification. The Engineer shall respond within five (5) days of receiving an adequate RFI. RFI responses provide clarification of Contract Documents and do not modify them; a formal Change Proposal is required if a contract modification is needed.

### **29.5 Notification Requirements**

Contractor shall notify the Engineer in advance of the following: testing required (48 hours' notice); intent to work outside regular working hours (72 hours' notice); request to shut down facilities or utilities (2 weeks' notice); proposed utility connections (2 weeks' notice); required observation by Engineer or inspection agencies prior to covering Work (72 hours' notice); and training (1 week's notice).

## **ARTICLE 30: CERTIFICATE OF FINANCE OFFICER**

---

The City certifies that funds are available and appropriated for this Contract in the amount of \$ \_\_\_\_\_ as required by North Carolina law and the Local Government Budget and Fiscal Control Act. This Contract is contingent upon the non-appropriation clause in Section 31.4 and upon the availability of sufficient appropriations for each fiscal year of this Contract. The Finance Officer's certification is provided on the signature page of this Contract.

## **ARTICLE 31: GENERAL PROVISIONS**

---

### **31.1 Severability**

If any provision of this Agreement shall be held invalid for any reason, the remaining provisions shall not be affected if they may continue to conform with the purposes of this Agreement and the requirements of applicable law.

### **31.2 Force Majeure**

Neither Party shall be deemed to be in default of its obligations if and so long as it is prevented from performing such obligations by an act of war, hostile foreign actions, adverse governmental actions, nuclear explosion, earthquake, hurricane, tornado, or other catastrophic natural event or act of God.

### **31.3 Morality Clause**

If, in the sole opinion of the City, at any time Contractor or any of its owner(s), employee(s), or agent(s) engages in any one or more of the following actions, the City may immediately upon written notice terminate this Agreement: (1) bring disrepute, contempt, scandal, or public ridicule to the Actor; (2) subject the Actor to prosecution; (3) offend the community or public morals/decency; (4) denigrate individuals or groups in the community served by the City; (5) is scandalous or inconsistent with community standards or good citizenship; (6) adversely affect the City's finances, public standing, image, or reputation; (7) is embarrassing or offensive to the City or may reflect unfavorably on the City; or (8) is derogatory or offensive to one or more employee(s) or customer(s) of the City.

### **31.4 Non-Appropriation**

Notwithstanding any other provisions of this Agreement, payments due from the City are from appropriations and monies from the City Council and other governmental entities. In the event sufficient appropriations or monies are not made available to the City to pay the terms of this Agreement for any fiscal year, this Agreement shall terminate immediately without further obligation of City.

### **31.5 Independent Contractor**

Contractor is an Independent Contractor and shall undertake performance of the services pursuant to the terms of this Agreement as an Independent Contractor. Contractor shall be wholly responsible for the methods, means, and techniques of performance. City shall have the right to observe such performance but shall not have the right to supervise methods and techniques.

### **31.6 Amendment**

Any changes mutually agreed upon by the City and Contractor shall be incorporated herein by written amendment to this Agreement. No oral understanding or agreement not incorporated in writing and signed by the Parties hereto shall be binding.

### **31.7 Entire Agreement**

This Agreement constitutes the entire agreement between the Parties. No modification, addition, deletion, or other change shall be effective unless and until such changes are reduced to writing and executed by the authorized officers of each Party.

### **31.8 City's Terms Supersede**

To the extent a conflict exists between the terms of this Agreement and the terms and conditions in any of the attachments to the Agreement, the terms of this Agreement shall govern, except that federal requirements in Article 17 shall supersede conflicting state or local requirements to the extent of any conflict.

### **31.9 Survival of Terms**

All warranties, covenants, and representations contained within this Contract shall continue in full force and effect for three (3) years after the execution and delivery of the final product, act, or service taken in furtherance of this Agreement. This Section does not extend or modify the warranty periods specified in Article 15 or applicable manufacturer warranties. Survivability shall not be rendered null or void by the termination or natural expiration of this Agreement.

### **31.10 Protest**

Protests related to this procurement must be addressed to the Purchasing Manager for City of Fayetteville, 433 Hay Street, Fayetteville, NC 28301, and shall be received in writing within five (5) calendar days of bid award. Responses will be provided in writing not later than seven (7) calendar days following receipt of said protest. After exhausting all City administrative remedies, a protester may escalate to FTA as the Federal grantor agency, but FTA review is limited to: (1) violations of federal law or regulations; and (2) violations of the City's protest procedures for failure to review a complaint or protest. See Section 20.4 for FTA protest escalation scope.

### **31.11 Singular/Plural**

Whenever used herein, the singular shall include the plural, the plural the singular, and the use of any gender shall be applicable to all genders as the context may require.

## **EXHIBITS LIST**

---

**Exhibit 1:** Proposal / Bid Form (Attachment A)

**Exhibit 2:** Addendum Acknowledgment

**Exhibit 3:** Special Provisions and Specifications (ITB Attachments A–O including FTA Requirements, Bid Price Sheet, Drawings)

**Exhibit 4:** Bond Forms (Performance Bond and Payment Bond per N.C. Gen. Stat. § 44A-33)

**Exhibit 5:** Licenses and Certifications (NC General Contractor License, DBE/SDBE Certifications)

**Exhibit 6:** Lien Waiver Forms (Subcontractor and Supplier)

**Exhibit 7:** Certificate of Insurance (COI naming City of Fayetteville and FAST as Additional Insureds)

**Exhibit 8:** Pay Application Form and Schedule of Values Template

**Exhibit 9: Change Order Request Form**

**IN WITNESS WHEREOF**, the parties hereto have executed this Contract as of the day and year first written above.

**CONTRACTOR:**

Firm Name: \_\_\_\_\_  
\_\_\_\_\_

By: \_\_\_\_\_

Print Name: \_\_\_\_\_  
\_\_\_\_\_

Title: \_\_\_\_\_  
\_\_\_\_\_

Date: \_\_\_\_\_  
\_\_\_\_\_

NC General Contractor License #: \_\_\_\_\_  
\_\_\_\_\_

License Classification: \_\_\_\_\_  
\_\_\_\_\_

**CITY OF FAYETTEVILLE, NC (FAST):**

By: \_\_\_\_\_

Print Name: \_\_\_\_\_  
\_\_\_\_\_

Title: \_\_\_\_\_  
\_\_\_\_\_

Date: \_\_\_\_\_  
\_\_\_\_\_

Attest: \_\_\_\_\_  
\_\_\_\_\_

City Clerk

**APPROVED AS TO FORM:**

City Attorney: \_\_\_\_\_ Date: \_\_\_\_\_

**CERTIFICATE OF FINANCE OFFICER:**

The undersigned Finance Officer of the City of Fayetteville certifies that this Contract has been pre-audited in the manner required by the Local Government Budget and Fiscal Control Act, and that funds have been appropriated and are available for this Contract in the amount of \$ \_\_\_\_\_.

Finance Officer: \_\_\_\_\_ Date: \_\_\_\_\_